



Port of the Islands

PRELIMINARY ENGINEERING REPORT

NEW WATER TREATMENT PLANT

Prepared for

Port of the Islands Community Improvement District  
Naples, Florida

June 10, 2009

Updated – October 13, 2009

Prepared by:

Ronald E. Benson, Jr., Ph.D., P.E.  
Hole Montes, Inc.  
Naples, Florida



Port of the Islands Community Improvement District  
New  
Water Treatment Plant

Executive Summary and Recommendations

The following information is a supplement to the earlier draft Preliminary Engineering Report prepared by Hole Montes, Inc. which was prepared to assist in establishing a budget for the new water treatment plant along with establishing future water use and conservation planning during water use permitting by the SFWMD.

As preliminary design has progressed on the new water treatment plant, a few key decisions need to be confirmed in order to continue to move the project forward. The site planning considerations are moving forward on a parallel track and have incorporated the preliminary design decisions identified in this report.

1. It is recommended that the new water treatment plant be designed using "energy efficient" reverse osmosis membranes.
2. It is recommended that provisions be made that will allow the blending of a portion of the raw filtered water around the reverse osmosis membranes. This has the potential to result in a reduction in post treatment chemicals.
3. It is recommended that the water from the wellfield be discharged into a raw water tank (approximately 10,000 gallons) at the new water treatment plant. This will maintain as low a pressure as possible on the raw water line resulting in maximum rate of pumping from the wells and minimum pressure on the existing older pipeline in the wellfield.
4. It is recommended that a common feed pump provide flow to the three reverse osmosis skids with an in-line strainer on the pump discharge and prior to feeding water to the skids. This will minimize any potential damage to the cartridge filters and remove sand and other material which may otherwise reduce the life between changing the cartridges in the cartridge filters. The pump which will transport the water from the on-site storage tank will provide sufficient pressure for operation of the in-line strainer.
5. It is recommended that the membrane skids each be provided with pumps which have variable frequency drives which will allow for adjustment of the feed flow rate and pressure to the membranes. This will allow for operation of either two skids at 200 gpm or three skids at 165 gpm feed flow as well as allow for meeting both initial feed pressure as well as increased feed pressure after the membranes have aged.
6. It is recommended that the Engineer begin discussions with two or three potential water treatment equipment and installation contractors to identify their interest in the project and to solicit comments to draft project scope and specifications. This should minimize possible issues later in the project. This will be done concurrently with processing of the County zoning and SDP applications.

7. It is recommended that the Engineer bid the supply and installation of the water treatment equipment prior to completion of the design of the water treatment plant building. The bid specifications for the supply and installation of the water treatment equipment will include submittal of shop drawings of major systems with a short turn around time to allow finalizing of the building structural design to match the dimensions of the successful bidder's system.
8. It is recommended that the contract with the water treatment supply and installation contractor include provisions for payment for a line item for the shop drawings and coordination assistance during design (with a percentage of total project cost provided in the bid form by the Engineer). In addition, it is proposed to provide a line item on the bid form to be paid following fabrication and manufacturing of the water treatment skids (with inspection by the Engineer) and storage of the completed systems prior to installation (a percentage of total project cost will be provided in the bid form prepared by the Engineer). Another bid item will be associated with startup and testing of the system.

### Consideration of various membrane options

Information was solicited from five potential membrane system providers. Two of the system providers provided options for reverse osmosis membranes and two provided options for nanofiltration membranes. The fifth system provider provided cost information for a reverse osmosis system but did not provide treatment performance information. All vendors were informed that the information being submitted was for preliminary design purposes and would be used to help establish a preliminary project budget. Generally, all of the system providers submitted budget type pricing which was similar and was appropriate for use in establishing the budget for the project without having to make the decision at that time of which treatment system to include in detailed design and development of bid specifications.

One of the reverse osmosis membrane system providers elected to propose a two-stage system including an intermediate booster pump, one proposed a two-stage system without booster pump, and another elected to propose two options using a two-stage system without intermediate booster pump along with the use of bypassing a portion of the feed flow around the membrane process. One of the nanofiltration system providers elected to propose a three-stage system and the other elected to propose two options using a two-stage system. To some extent, the system which each system provider submitted was influenced by the request from the Engineer. The requests by the Engineer were made in order to obtain information on a variety of prospective treatment options. It is understood that each of these system providers, as well as potentially others, could potentially be able to make a formal submittal at the time of project bidding for whichever type of system configuration is selected. In addition, the size of the production capacity of each process train was different which allowed assessment of how many process trains to select. As a result, the capacity of each system has been normalized to 100 gpm of feed flow in order to easily calculate percent of feed flow resulting in product water (or recovery). The capacity of each well is 200 gpm and it has been decided to install three membrane treatment units, each with a maximum feed flow of 200 gpm to match the maximum permitted wellfield production of 600 gpm. Therefore, the normalized flows can simply be multiplied times two in order to obtain approximate design flows for each option considered. In this manner, just like there are three wells with the expectation that only two would be in service at a time (with the third rotated as a resting well), it is expected that normal operation of the water treatment plant would be using two of the three membrane treatment units at a time (with the third rotated as an available standby unit to allow for scheduled maintenance or unexpected repair). The design will also allow for the potential in the future to add an additional treatment unit in the event of system expansion beyond current expectations.

The concentrate water from the water treatment plant will be blended with the reuse water and raw well water in order to provide irrigation water. The result of blending of the concentrate with raw water and reuse water will be an increase in the mineral content of the irrigation water to some extent over that of the raw well water. As an example, if 100,000 gallons of product water is produced then 25,000 gallons of concentrate will be produced and approximately 75,000 gallons of reuse water will also likely be produced.

Therefore, for every 125,000 gallons of raw well water going to the water treatment plant approximately 100,000 gallons will be available for potable water use and approximately 100,000 gallons of irrigation water will be available. If the total irrigation demand were to be 400,000 gallons then an additional 300,000 gallons would be needed from the wellfield. In this example, the total water from the wellfield would be 425,000 gallons. The minerals from 425,000 gallons would end up concentrated into 325,000 gallons of blended irrigation water (raw water plus concentrate) which would then be blended with 75,000 gallons of reuse water for a resulting mixture of 400,000 gallons of irrigation water. Due to this blending, the mineral content of the irrigation water will be slightly higher than the raw well water. A daily use of 425,000 gallons from the wellfield is equal to two wells being pumped at 200 gpm for 18 hours per day.

#### Option One: Two-stage RO with intermediate booster pumping

The first option provided here is a two-stage Reverse Osmosis system with a booster pump located between the two stages. The feed pressure would be approximately 100 psi and the pressure boost between stages would be approximately 40 psi. This type of system allows for a lower feed pressure offset by boosting the pressure of the concentrate leaving the first stage which is approximately 50% of the feed flow. This option is illustrated schematically in Figure 1. The percent recovery for an individual stage of a membrane process is influenced by the membrane flux (essentially the rate of flow per unit area of membrane), feed pressure, and water quality. A couple of things to consider in this example are that the water entering the second stage is the concentrated water from the first stage which will reduce the relative recovery while the pressure is being boosted which will offset the otherwise reduction in recovery. This along with the relative flux for the second stage being slightly lower results in a higher recovery for the second stage than the first stage. The permeate from both stages are blended, resulting in the product water. As can be seen from Figure 1, the combined product water is 80 percent of the feed water and the concentrate is 20 percent. Essentially all of the minerals in the feed water are concentrated in the concentrate (or reject water). The resulting product water will be very low in mineral content and as a result will require some chemical addition in order to improve the stability of the water. Keep in mind that distilled water can actually be very corrosive and also not taste as good to most people as water with some mineral content. The same is true with R.O. water without post treatment.

#### Option Two: Two-stage RO

The second option is a straight-forward two-stage RO system without intermediate booster pumping. This option is illustrated schematically in Figure 2. The difference between this option and Option One is that the residual pressure in the reject water is the pressure available to produce permeate from the second stage and since this is less than operation when using a booster pump then the percent recovery for the second stage is less than when a booster pump is provided. This system also has 80% recovery and will produce water quality similar to Option One.

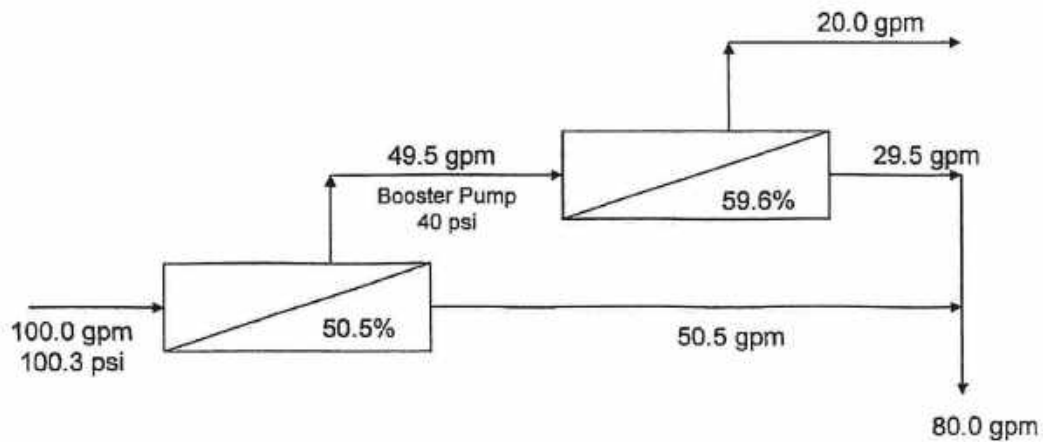

### Option 1: Two-stage Reverse Osmosis membranes (with intermediate booster pumping)

(flow numbers represent a normalized feed flow of 100 gpm,  
numbers noted as percent represent percent permeate for that stage)

Figure 1 – Two-stage RO with intermediate booster pumping

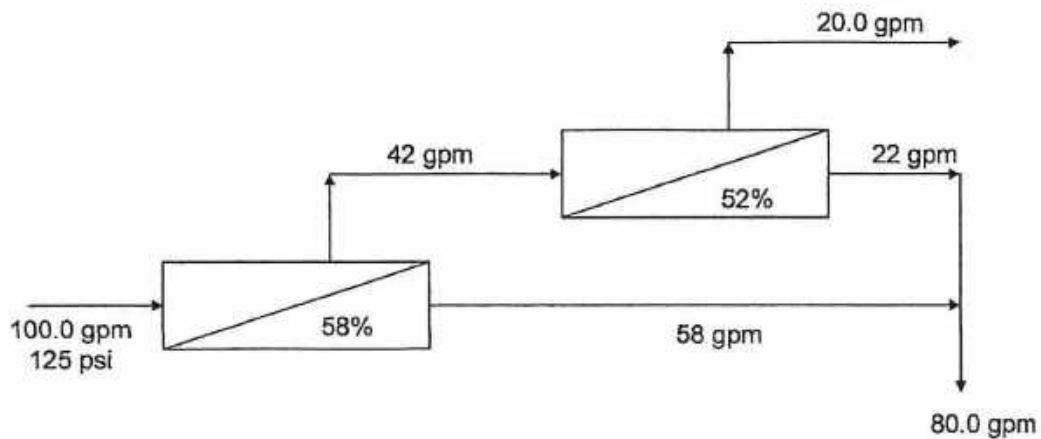

### Option 2: Two-stage Reverse Osmosis membranes

(flow numbers represent a normalized feed flow of 100 gpm,  
numbers noted as percent represent percent permeate for that stage)

Figure 2 – Two-stage RO without intermediate booster pumping



### Option Three (A): Two-stage RO with blending of 10% bypass water

This option includes two stages of reverse osmosis without an intermediate booster pump. This option is illustrated schematically in Figure 3. As a result, the feed water pressure needs to be higher (150 psi), although the higher pressure for the first stage results in a greater recovery in the first stage for this option than the first stage in Option One. Without an intermediate booster pump, the feed pressure to the second stage is not as great as the second stage in Option One resulting in a lower recovery in the second stage for this option than the second stage in Option One. These two considerations can be seen to counter balance one another between these two system configurations when it comes to the amount of energy required to produce the same volume of product water, although the system in Option One is generally slightly more energy efficient (but requires an additional pump for the intermediate pressure boost). Another variation between this option and Option One is that approximately 10% of the feed flow is bypassed around the membrane system in order to reduce the amount of water requiring membrane treatment as well as to blend in some of the minerals which occur naturally in the raw water. The result of blending is to produce a product water which is not quite as pure as the product from the reverse osmosis membrane but will require less post treatment chemical adjustment. The blended product water (81.8 gpm) is made up of 72.3 gpm of reverse osmosis permeate and 9.5 gpm of bypassed water. The combination of blending of water which was not treated by reverse osmosis with water treated by reverse osmosis results in a total energy requirement for Option Two which is similar to Option One.

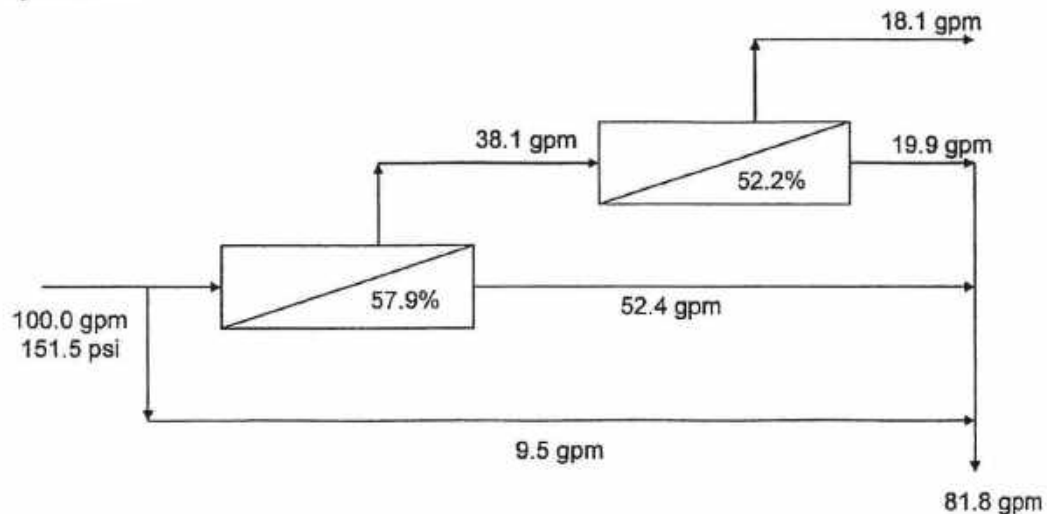

**Option 3A: Two-stage Reverse Osmosis membranes with bypass for blending (example A)**

(flow numbers represent a normalized feed flow of 100 gpm, numbers noted as percent represent percent permeate for that stage)

Figure 3: Two-stage RO with 10% Bypass

### Option Three (B): Two-stage RO with blending of 15% bypass water

Option Three (B) is similar to Option Three (A), except the amount of water which is bypassed around the reverse osmosis membrane is 15% of the feed water. This option is illustrated schematically in Figure 4. The blended product water (83.0 gpm) is made up of 68 gpm of reverse osmosis permeate and 15 gpm of bypassed water.

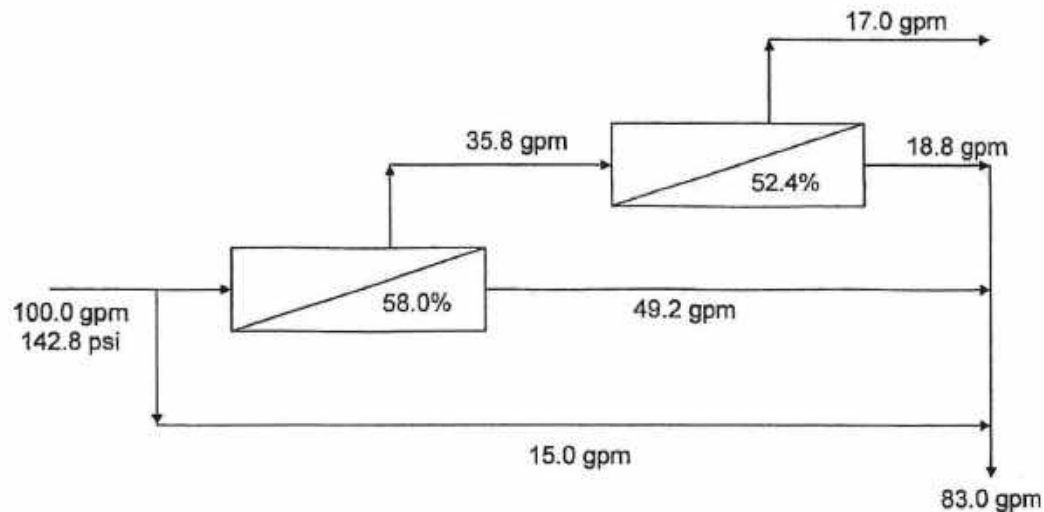

### **Option 3B: Two-stage Reverse Osmosis membranes with bypass for blending (example B)**

(flow numbers represent a normalized feed flow of 100 gpm, numbers noted as percent represent percent permeate for that stage)

Figure 4: Two-stage RO with 15% Bypass

### Option Four: Three-stage Nanofiltration

Option Four consists of the use of a different type of membrane. It uses nanofiltration membranes. The primary difference between nanofiltration membranes and reverse osmosis membranes is the size of the pores in the membrane which result in a different amount of removal of many of the minerals and other chemicals found in the raw water. This option is illustrated schematically in Figure 5. This proposal is based on a cascading system of three stages. The concentrate from the first stage becomes the feed for the second stage and the concentrate from the second stage becomes the feed for the third stage. As can be seen from Figure 4, the percent of feed to each stage which becomes product water decreases as the concentration of minerals in the feed water to each stage increases. The feed water pressure would be approximately 100 psi. This is similar to the feed pressure for Option One. As can be noted from Figure 4, the treatment of 100 gallons of water results in 75 gallons of product water, or to normalize on product water



Option Four would require 133 gallons of well water to produce 100 gallons of product water compared to 125 gallons of well water to produce 100 gallons of product water for Option One. As the concentrate water will end up being used for irrigation water, this difference in recovery rates is not that significant.

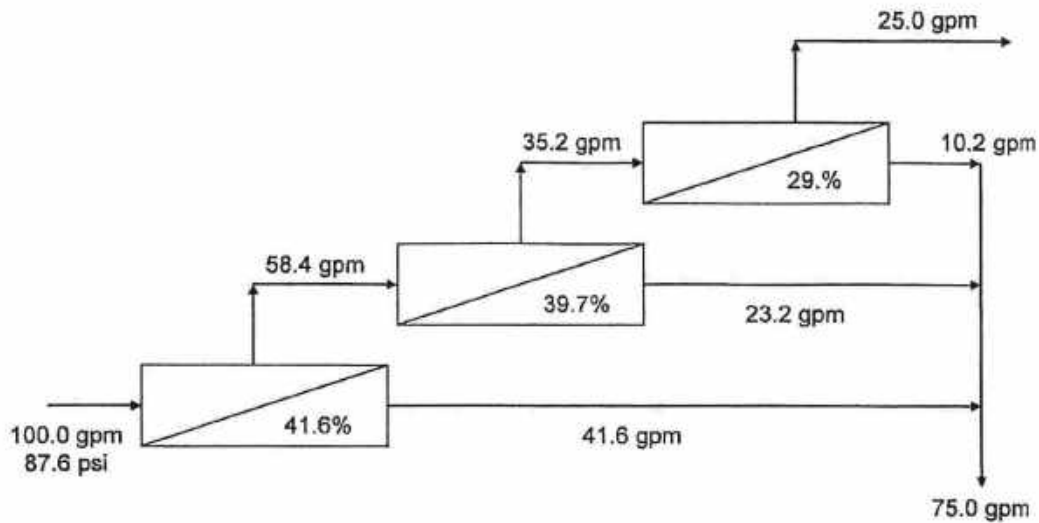

#### Option 4: Three-stage Nanofiltration membranes

(flow numbers represent a normalized feed flow of 100 gpm, numbers noted as percent represent percent permeate for that stage)

Figure 5: Three-stage Nonfiltration

#### Option Five (A): Two-stage Nanofiltration

This option is similar to Option Four, except it uses two stages instead of three stages of membranes. This option is illustrated schematically in Figure 6. The system provider adjusted the membranes and operational pressures to provide an 80 percent recovery. The feed pressure is approximately 90 psi.

#### Option Five (B): Two-stage Nanofiltration

This option is similar to Option Five (B), except the operational pressures between the two stages have been adjusted through use of a throttling valve in order to change the flow distribution between stages. This option is illustrated schematically in Figure 7. The primary difference between Option Five (A) and Five (B) is the resulting product water quality. The feed pressure is approximately 80 psi.

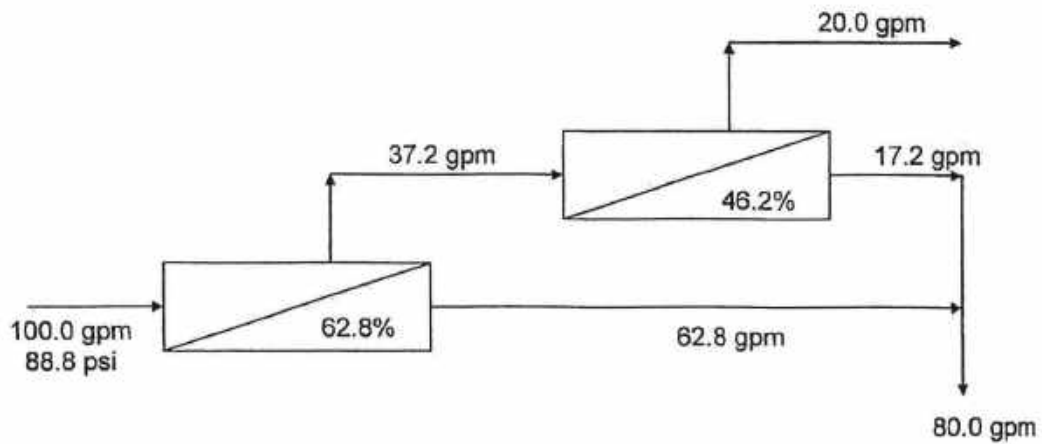

### Option 5A: Two-stage Nanofiltration membranes (Example A)

(flow numbers represent a normalized feed flow of 100 gpm,  
numbers noted as percent represent percent permeate for that stage)

Figure 6: Two-stage Nonfiltration (higher level of hardness removal)

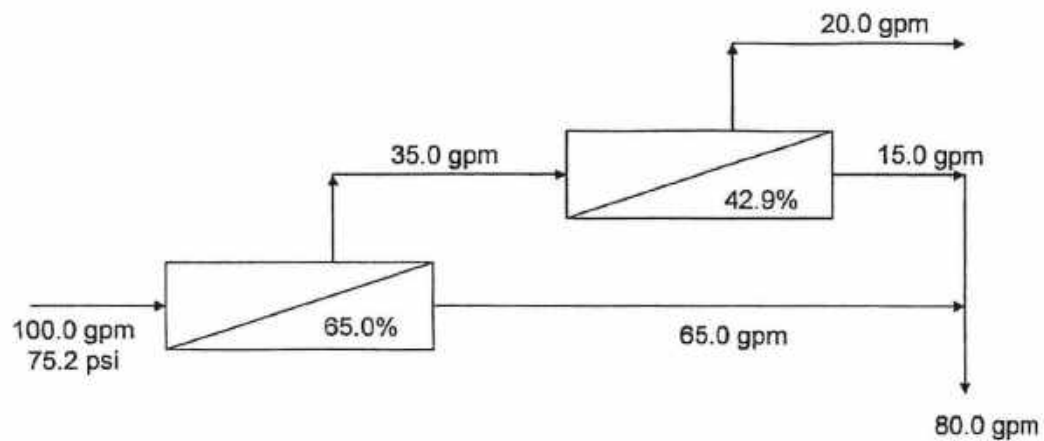

### Option 5B: Two-stage Nanofiltration membranes (Example B)

(flow numbers represent a normalized feed flow of 100 gpm,  
numbers noted as percent represent percent permeate for that stage)

Figure 7: Two-stage Nonfiltration (lower level of hardness removal)

### Option Six: Two-stage Energy Efficient R.O.

This option is similar to Option Two except it uses a different R.O. membrane. This R.O. membrane will require a lower feed pressure and will produce a slightly different permeate quality (a slightly lower rate of rejection of minerals – higher amount of minerals passing the membrane into the permeate water). This option was configured to allow operation at a pressure more similar to the nanofiltration options which would also result in lower power consumption to produce the same amount of water as use of another R.O. membrane.

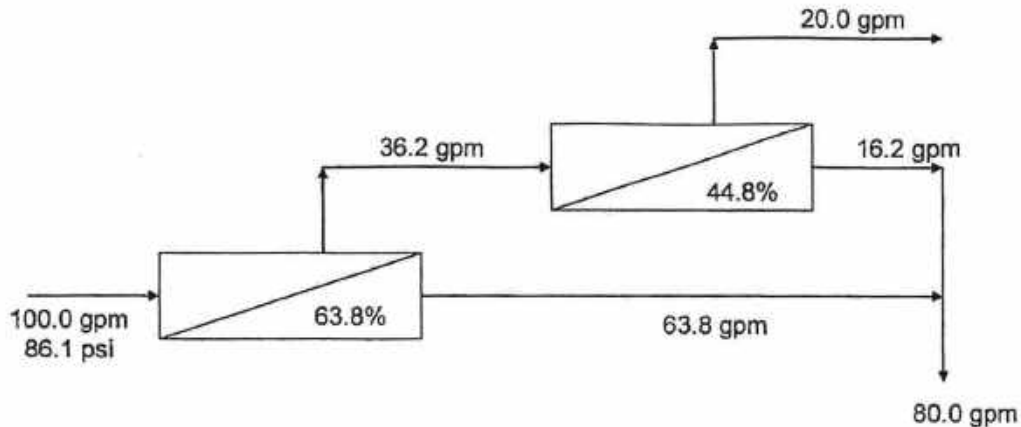

### Option 6: Two-stage Energy Efficient Reverse Osmosis membranes

(flow numbers represent a normalized feed flow of 100 gpm,  
numbers noted as percent represent percent permeate for that stage)

Figure 8: Two-stage Energy Efficient Reverse Osmosis (lower feed pressure)

#### Product water considerations

Each of the above Options has a different level of removal of the minerals and chemicals which are present in the raw water. Options One and Two will have the lowest concentration of chemicals in the product water as they use the type of membrane with the highest rejection of these chemicals. Options Four and Five use a type of membrane with a lower level of rejection of these chemicals and as a result will have a higher concentration in the product water than Option One. Options Three (A) and Three (B) will have higher concentrations in the product water than Option One due to the blending of raw water with the permeate from the membrane treatment process. Option Six is similar to Options One and Two, except a slightly different R.O. membrane is used resulting in a slightly higher mineral content in the product water. Table 1 provides a comparison between these four options for a list of typical chemical parameters along

with a comparison with the raw well water. The system provider for Option Two did not submit water quality expectations for their system, although they would be expected to be similar to Option One.

The hardness in water is primarily a result of the combination of the calcium and magnesium in water and can be calculated using the concentration of these two ions. The typical classification of harness of water is provided in Table 2.

Table 2: Hard water classification

Hardness Range (mg/l as CaCO <sub>3</sub> )	Description
0 – 75	Soft
75 – 100	Moderately hard
100 – 300	Hard
300 +	Very hard

As can be seen from Table 2, the raw water from the wellfield (identified in Table 1) can be considered as being very hard, whereas the product water from all of these treatment options can be considered as being soft. The product water from Option One can be considered as very soft. Another parameter that is important when it comes to the stability of the water in pipelines and plumbing is the alkalinity of the water. This is a measure of the amount of acid which needs to be added in order to adjust the pH of the water. A water with little alkalinity is one which will generally be corrosive as this can be an indicator of stability of the water when considered in combination with the hardness. As a result, it is likely that the product water from Options One, Two, and Six will require the addition of post-treatment chemicals in order to reduce the potential for corrosion. Options Three (A) and Three (B) were developed with the intention of yielding water with hardness of between 40 and 60 mg/l (as CaCO<sub>3</sub>) and the hardness for Option Four is simply that which results from three-stage nanofiltration treatment of this water. Options Five (A) and Five (B) were developed with the intention of yielding water that is softened, but at two different hardness levels.

One point that should be taken from this analysis is that either the process of blending filtered raw water with RO treated water or adjustment of the combination of nanofiltration process feed pressure and throttling the permeate valve(s) allows for an adjustment in product water quality by changing the distribution of flow between stages. As can be seen in Table 1, within a range of possible values, the amount of filtered raw water to bypass around the RO treatment unit can be adjusted as an operational parameter to achieve a desire product water hardness and alkalinity.

Table 1: Comparison between Chemical Concentrations in Product Water

	Raw Water	Option 1 R.O.	Option 3A R.O. w/ blending	Option 3B R.O. w/ blending	Option 4 N.F.	Option 5A N.F.	Option 5B N.F.	Option 6 R.O.
Chloride, mg/l	69	0.9	8.7	13.1	14.2	15.2	31.5	1.4
Sodium, mg/l	36	1.2	5.7	8.0	7.0	13.4	20.4	6.5
Calcium, mg/l	120	1.5	15.0	22.7	9.6	10.5	30.3	4.9
Magnesium, mg/l	4.7	0.06	0.59	0.89	0.40	0.41	0.71	0.19
Potassium, mg/l	0.79	0.02	0.10	0.20	0.17	----	----	----
Sulfate, mg/l	36	0.3	4.1	6.3	1.1	1.3	3.1	0.3
Alkalinity, mg/l as CaCO <sub>3</sub>	358	6.6	47.9	70.8	32.9	41.9	92.5	24.9
Calculated Hardness mg/l as CaCO <sub>3</sub>	320	4	40	60	30	30	75	13
Feed Pressure, psi		100 + 40 (booster)	150	140	90	90	80	90

### Pretreatment Considerations

Each of the system providers who submitted the information compiled above, also submitted recommendations on the type of pretreatment which should be performed prior to the membrane process.

Option One – recommended cartridge filtration, along with scale inhibitor feed system.

Option Two – recommended cartridge filtration, along with scale inhibitor feed system.

Options Three (A) and Three (B) – recommended iron removal prior to the membranes using manganese dioxide catalytic media filtration, along with scale inhibitor feed system.

Option Four – recommended multi-media filters, followed by carbon filters, along with scale inhibitor feed system.

Options Five (A) and Five (B) – recommended cartridge filtration, along with scale inhibitor feed system.

Option Six – recommended cartridge filtration, along with scale inhibitor feed system.

The option of using reverse osmosis along with flexibility in being able to bypass filtered raw water has some advantages. It allows for operational adjustments to produce the desired water quality including making periodic adjustments in the event the feed water quality changes with time. As the product water from the treatment units is the highest purity, adjustments using post treatment chemicals can be made to produce the desired water quality in comparison to potential future concerns if using nanofiltration membranes and questions as to whether they would continue to meet product water quality in the event of a future change in raw water quality. The relative costs of these two systems is not significant when compared to the overall cost of the project, both on a capital cost basis and operational cost basis.

### Recommendations

Additional sampling is recommended to better establish the iron concentration in the raw water from the wellfield and to include this information in the system specifications in order to allow each bidder to include an alternate price for additional pretreatment if they feel it necessary for the system they are proposing.

It is recommended that bid specifications be prepared for reverse osmosis systems which would have bypass piping to allow for blending of raw filtered water around the RO

membranes to allow for adjustment of the product water hardness and alkalinity. This would allow for operational flexibility and opportunity to reduce post-treatment chemical addition. In addition, post-treatment chemical addition storage and feed systems should be installed to also allow their use in the event that the blending of the filtered well water alone is insufficient to provide a stable product water.

It is also recommended that each system provider be asked to bid a base system without an intermediate booster pump as for a facility of this size the requirement of additional equipment to operate and maintain does not justify the small increase in potential power savings. A series of alternative bid items will be provided to allow for possible differences in recommended pretreatment. The bid price for the base bid will be binding, whereas the bids for pretreatment and other options will be negotiable with the low bidder following award. A bid item will include coordination with the Engineer of Record during final design of the project to allow layout of the building, piping, electrical and mechanical systems to allow installation of their treatment system with the minimum of potential issues between building construction contractor and the treatment equipment provider/installer during construction.

#### Considerations in Sizing Membrane Skids and Permitted Capacity Requested

There are a number of considerations which need to be incorporated in sizing the volumetric flow capacity for each membrane skid. One relates to having a sufficient number of skids such that with one skid offline, either for scheduled maintenance or unscheduled repairs, that sufficient capacity remains to meet the community's needs. This generally means increasing operating hours per day on the remaining skids to make up for the skid that is offline. Another factor relates to the number of hours per day operation during a typical day. In addition, in order to minimize raw water storage, the production capacity of the wellfield must also be considered.

Normally, in order to keep the capital cost of the water treatment plant as reasonable as possible, the number of hours of operation per day should be on the order of 16 to 24 hours per day when meeting maximum day flow demands. Due to the size of this utility, that may not be practical from a staffing standpoint. The trade off is to build a larger capacity treatment plant and operate it fewer hours per day. Another consideration, when making this decision, is that additional finished water storage is needed as water is being produced during only a portion of the day which must be stored for use by the customers during the remainder of the day when the water treatment plant is not being operated.

Earlier this year, the wellfield pumps and electrical systems were upgraded. This has resulted in the ability to pump 200 gpm from each of the two wells simultaneously (combined total of 400 gpm). Recent testing of the wells confirms the ability to pump 400 gpm with two pumps in service. This recent testing also allowed for measurement of the pressure in the pipeline at the wells along with pressure in the pipeline at the water treatment plant. The difference in these pressures is due to the friction loss in the pipeline between the wellfield and the water treatment plant. Based on these



measurements, along with operation of each pump independently, we have been able to predict the maximum pumping capacity from the three wells using the existing pipeline and the new pumps. The anticipated maximum pumping capacity should be 500 gpm with all three wells in service. The wellfield electrical upgrades included installation of equipment that would potentially allow installation, at some future date, of larger pumps than were installed at this time. The reason for not installing the larger pumps at this time was based on the following considerations.

- To reduce the amount of electrical power consumed in operating the wellfield by not oversizing the pumps at this time.
- To avoid operation of the existing older pipeline at high pressures to extend the life of the pipeline as long as possible.
- To avoid having to pay Lee County Electric Coop to upsize the power lines which provide power to the wellfield.
- The need for more than 500 gpm is not envisioned at this time and it is likely that a future upgrade would occur after the new pumps have reached their useful life.

It is envisioned that at some point in the future that the wellfield will be able to provide 600 gpm which is the maximum permitted capacity for the three wells. For this reason, it is recommended that the new water treatment plant membrane skids be sized to handle the future condition of 600 gpm, or 200 gpm per well times three wells with each membrane skid handling the raw water from one well. It is also recommended that each membrane skid be designed with a VFD operated feed pump that can adjust the feed flow and pressure to operate between 165 gpm and 200 gpm. This will also allow the system to operate at the pressure needed for new membranes as well as operate at a higher pressure in the future as the membranes age.

In this manner, with two wells in service and two membrane skids in service the feed flow would be a maximum of 400 gpm and a product water flow of 320 gpm and with three wells in service and three membrane skids in service the feed flow would be at 500 gpm and a product water flow of 400 gpm.

Maximum daily production capacity (operation for 24 hr/day) would be 576,000 gallons per day.

$$400 \text{ gpm} \times 60 \text{ min/hr} \times 24 \text{ hr/day} = 576,000 \text{ gpd}$$

The Recommended Phase I design capacity maximum day demand was predicted to be 280,000 gallons/day, which is 200% of current maximum day historic levels. This could be accomplished by operation of the new water treatment plant 12 hours per day on the day with the highest demand for potable water.

$$\frac{280,000 \text{ gal/day}}{400 \text{ gpm}} = 700 \text{ minutes/day or } 11.67 \text{ hours/day}$$

The Average day demand for potable water during peak season, associated with a maximum day demand of 280,000 gpd, would be 210,000 gpd. This would mean operation for less than 9 hours per day.

$$\frac{210,000 \text{ gal/day}}{400 \text{ gpm}} = 525 \text{ minutes/day or } 8.75 \text{ hours/day}$$

The Average day demand during the entire year, associated with a maximum day demand of 280,000 gpd, would be 150,000 gpd. This would require operation for between 4 and 8 hours most days during the year, or an annual average of around six hours per day.

$$\frac{150,000 \text{ gal/day}}{400 \text{ gpm}} = 375 \text{ minutes/day or } 6.25 \text{ hours/day}$$

Remember that this is at a future production level that is 200% of current demands so upon start-up, the number of hours per day will be one half of this, so not all of the units will be operated simultaneously.

In the event that one unit was out of service, even at the maximum day demand levels, this plant could produce sufficient water if operated 14.5 hours per day (2 out of 3 skids in service at 200 gpm feed water each). The trade off is that in the unlikely event of unscheduled repair to one skid during the highest flow day of the year that the facility would have sufficient capacity to produce sufficient water by having the operation team putting in some overtime and/or bringing in an off duty operator from a nearby facility.

At some point in the future, the wellfield can be operated through having LCEC replace a few miles of overhead power lines and transformers, along with replacement of the well pumps with larger horsepower pumps. This will allow maximizing the combined production capacity of the three wells at 600 gpm (approximately 25% additional raw water flow rate). This would raise the total production capacity at the treatment plant to 480 gpm (or 690,000 gpd operating 24 hrs/day). Note that this is more than 500% of current maximum daily demand. Therefore, even if future demand was to reach 300% of present demand (which is not expected), the treatment plant could meet this level of demand by operating 14.5 hrs/day on the one day per year with maximum demand, 11 hrs/day on a typical day during peak tourist season, or 8 hrs/day on a day with annual average demand.

It is believed that the above is a reasonable compromise between minimizing initial capital costs and minimizing annual operating costs, while also providing appropriate level of reliability system redundancy. Therefore, it is recommended that the specifications be prepared for 3 skids at 200 gpm feed at 80 percent recovery. There still remains a question as to what capacity do we request as the permitted maximum day capacity.

The capacity we use should for permitting should be what we feel we can sustain in a reasonable number of hours of daily operation with two out of three units in service. We

do not see a down side in making this a higher number other than the potential impact on permit required hours per day for the operator to be on site. The obvious upside to a higher permitted capacity is to avoid future permitting issues with FDEP as actual demand approaches capacity. Water treatment plants are permitted at one time, prior to construction, and do not have the five-year permit renewal cycle like wastewater treatment plants.

FDEP would consider the proposed treatment plant to be a Category II Class C facility. If the permitted capacity is under 500,000 gpd, this would require "staffing by Class C or higher operator: 3 hours/day for 5 days/week and one visit on each weekend day." The minimum staffing is doubled if the capacity is greater than 500,000 gpd. Therefore, the permitted capacity needs to be less than 500,000 gpd.

If we take the initial maximum production of 160 gpm per skid, no bypass for blending, operation of two out of three skids, and 24 hrs/day operating time, this is equal to 460,800 gpd. This can be compared to a maximum production of 576,000 gpd operating all three skids 24 hrs/day, including bypass for blending. It would be reasonable to establish the permitted capacity of the WTP at 460,000 gpd since it will replace the existing facility which was previously permitted at 435,000 gpd (24 hrs/day operation with all units in service). This would also be less than the 500,000 gpd threshold with regard to operation staffing requirements.

#### Pump Design and Specification Considerations

When designing the pumping equipment to feed flow to a membrane system it is important to size the pump for the anticipated future conditions. One condition is that as the membranes are used and age that it will take more pressure to provide the same volumetric flow of permeate through the membrane for a constant feed flow rate. This can be illustrated in Figure 9 as the difference between the line identified as 160 gpm permeate when new versus 160 gpm permeate when old. At a feed water condition of 100 mg/l chlorides this is the difference between 78 and 96 psi. Another potential consideration is the potential that the feed water condition to change with time. In the above example, the pressure increase necessary to handle a change from 100 mg/l chlorides to 500 mg/l chlorides is used. In this example, an additional increase in feed pressure from 98 psi to 115 psi would be needed to handle this contingency planning. A compromise position would be to allow for a slight reduction in permeate production capacity in exchange for being able to provide contingency planning for possible future increase in chloride concentration. In the example illustrated in Figure 9, a reduction in permeate production of approximately 10 percent in the future in the event of an increase in chlorides from 100 mg/l to 300 mg/l would be the approximate tradeoff. This is a reasonable approach for a facility such as being planned for Port of the Islands as the proposed facility is being designed to operate considerably less than 24 hours per day and in the event of feed water quality deterioration in excess of what is anticipated were to occur then this could be accommodated in the future through an increase in run time of the facility.

**Pump Design Considerations (200 gpm feed per skid)  
Membrane Age and Increase in Raw Water Chloride Concentration**

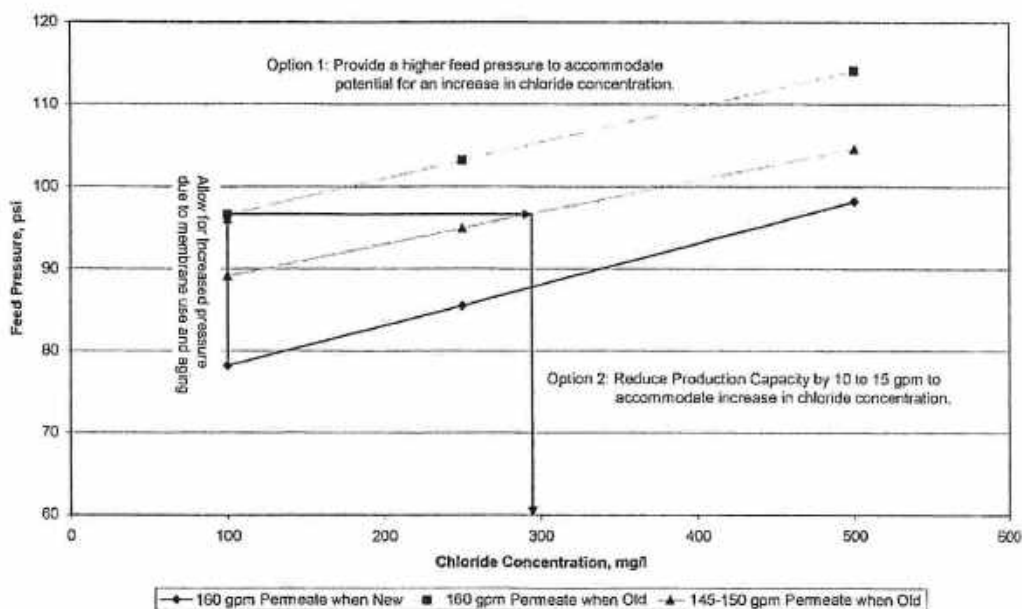

Figure 9: Pump Design Considerations

Considerations in Preparing Bid Specifications

Figure 10 illustrates the major components to be included in the proposed reverse osmosis water treatment plant. A scope of supply will be prepared for the primary water treatment equipment components which will include installation of these systems within the proposed building which will be constructed under a separate construction contract.

At this time, the general scope of supply around which the bid specifications are proposed to be written for the major equipment has been identified as outlined below.

1. In-line strainers
2. Acid storage and feed systems
3. Anti-scalent storage and feed systems
4. Three Reverse Osmosis treatment skids, each to include
  - a. Cartridge Filters
  - b. Dedicated feed pump with VFD (with ability to control pumping rate based on desired feed flow rate per skid)
  - c. Two-stage membrane system with
    - i. maximum membrane feed pressure of 100 psi at chloride concentration of 100 mg/l (@ flux decline of 7% per year for 5 years)
    - ii. minimum feed flow of 200 gpm

- iii. minimum permeate flow of 160 gpm
- iv. minimum recovery of 80%
- v. minimum chloride rejection of 90%
- vi. minimum calcium rejection of 90%
- d. Bypass piping with control valve to allow blending of raw water with permeate at a maximum flow of 30 gpm
- e. Control panel (PLC) for each skid with 4-20 mA output to allow integration by others into a Utility-wide SCADA system
- 5. Cleaning system for Reverse Osmosis membranes
- 6. Post-treatment systems to include
  - a. Degasification for removal of carbon dioxide
  - b. chemical storage and feed systems
    - i. pH adjustment to a finished water pH of between 6.8 and 7.2
    - ii. alkalinity and hardness adjustment
    - iii. corrosion inhibitor
  - c. chlorine storage and feed systems
  - d. ammonia feed system (for feeding post CT tank prior to finished water storage tank)

It is proposed that all yard piping and primary raw water feed piping into the building and primary product water piping leaving the building will be provided by the general contractor who will build the building and do the site work. The general contractor will also install the raw water booster pumps, finished water transfer pumps, and distribution system high service pumps. The building will be constructed with pipe trenches in the floor to allow installation of piping and tubing between various systems (such as pretreatment, post-treatment, and cleaning systems). The general contractor will also provide the all electrical systems, including the motor control centers and electrical cables to the Water Treatment Room for providing power to the various equipment supplied by the equipment supply and installation contractor.

At this time, the general scope of supply for the General Contractor is envisioned to include the following, although will be defined in detail as the design documents are prepared.

- 1. civil/site work
- 2. yard piping
- 3. building construction
- 4. electrical supply and distribution within the building
- 5. lighting
- 6. mechanical and HVAC
- 7. plumbing
- 8. floor trenches for process piping and tubing installation
- 9. feed water piping and finished water piping
- 10. raw water storage tank (approximately 10,000 gallons)
- 11. raw water feed pumps and piping
- 12. CT tank and piping

13. Finished water transfer pumps and piping
14. Distribution system supply pumps and piping

It is recommended that the above preliminary identification of the division of work between the General Contractor and the Equipment Supply and Installation Contractor be used as a starting point in discussions with potential Equipment Supply and Installation Contractors. These preliminary discussions should help in the development of the final bid specifications such that potential coordination issues between the two contractors can be minimized during development of the plans and specifications for the project. In addition, it is proposed to bid the Equipment Supply and Installation contract ahead of completion of the design of the building in order to be able to receive shop drawing submittals for the water treatment skids before finalizing the dimensions and locations of the pipe trenches. The bid specifications for the water treatment equipment will provide definitions of the work to be done during final design of the building by the equipment supply and installation contractor along with progress payments. Provisions will also be made for defining the earliest date at which the supplier may request inspection of the skids to establish a date upon which payment request may be submitted for stored materials as well as percentage of contract price which stored materials are reimbursable. This will help identify the risk to both parties by establishing a time when the equipment becomes the property of the CID and allow bidders to determine how to price their equipment for assembly and installation at a defined future date. Removing uncertainty from the bid will hopefully allow for better and more competitive pricing.



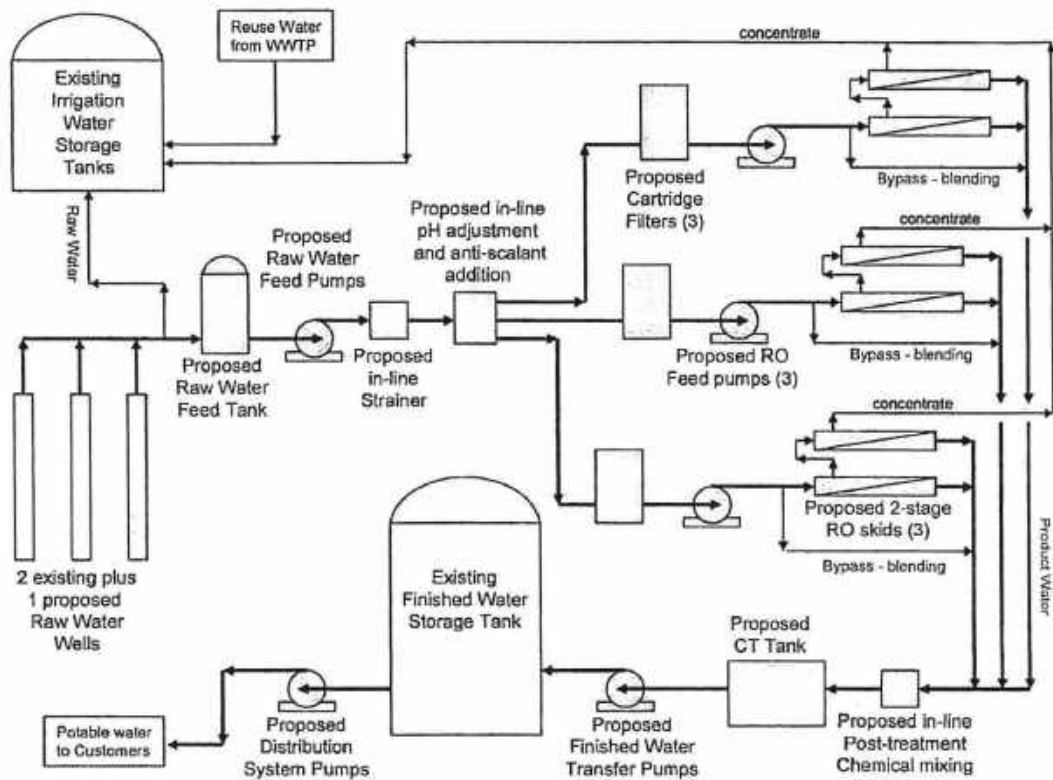

Figure 10: Process Flow Schematic – Proposed Reverse Osmosis Water Treatment Plant Project Scope Description





Port of the Islands

PRELIMINARY ENGINEERING REPORT

NEW WATER TREATMENT PLANT

Prepared for

Port of the Islands Community Improvement District  
Naples, Florida

June 10, 2009

Prepared by:

Ronald E. Benson, Jr., Ph.D., P.E.  
Hole Montes, Inc.  
Naples, Florida



**PRELIMINARY ENGINEERING REPORT**  
**PORT OF THE ISLANDS WATER TREATMENT PLANT**  
June 10, 2009  
Page 1

**EXECUTIVE SUMMARY**

The Port of the Islands Community Improvement District owns and operates the existing lime softening water treatment plant, located in the northeast quadrant near the end of Union Road. This facility was purchased more than 15 years ago when a private utility company in northern Collier County connected to the Collier County Utilities water system and declared it surplus. The existing water treatment plant is now more than 30 years old and has reached its useful life. It is becoming more and more difficult to be able to repair the corroded steel tank components and some of these areas with corroded metal are getting to the point of structural concern in addition to tank leaks. Water treatment technology has progressed since this water treatment plant was new and the existing lime softening treatment technology does not remove as much naturally occurring organic matter as the new treatment technologies. Newer membrane treatment technologies provide a much higher quality of potable water for the customers than does lime softening.

The current water supply source consists of two wells located approximately two miles northeast of the water treatment plant. Addition of a third well is currently under design and is anticipated to be operational by the end of calendar year 2009. Initially the third well will serve primarily to allow rotation of the wells with either one or two wells normally in service simultaneously. Eventually the well pumps may be upgraded to increase the production to the maximum amount permitted. These wells draw water from the Lower Tamiami aquifer with the large wetland areas north and east of the wells as the general recharge area. The naturally occurring organic matter in the well water is a natural byproduct of decomposition in the surficial layer of soil in the wetland areas surrounding the wells and recharging the surficial aquifer in this area. The water quality is fresh in this area of fairly rapid recharge with essentially no competing users. The water quality is influenced by the Fakha Union Canal and its connection to the Gulf of Mexico and as a result the water from the surficial aquifer has higher salinity as you move west from the existing wells toward the Fakha Union Canal. Test wells drilled near the existing water treatment plant can be described as brackish.

Two alternatives were developed for consideration. One alternative considered was for continued use of the existing wells with membrane treatment and the other alternative was for new brackish water wells with reverse osmosis treatment. Membrane treatment of the water from the existing wells was selected as being considerably lower cost. The plan includes construction of a new WTP consisting of three membrane skids with a raw water capacity of 200 gpm each (160 gpm product water each). The total WTP design capacity will be 480 gpm (equivalent to 600,000 gpd if all three skids operated 24 hours per day). The facility is being designed for an initial permitted capacity of 280,000 gpd (16 hours per day with two skids or 10 hours per day with all three skids in service). Concentrate will be discharged into the irrigation water storage tank and blended with reclaimed water from the wastewater treatment plant along with raw water from the same wellfield which provides the raw water for the WTP. If deemed necessary during

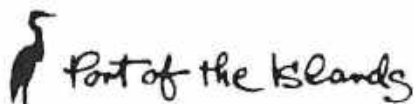

**PRELIMINARY ENGINEERING REPORT**  
**PORT OF THE ISLANDS WATER TREATMENT PLANT**  
June 10, 2009  
Page 2

permitting for the project, the concentrate could receive treatment using the existing sand filter and chlorine contact basin at the WWTP prior to discharge into the irrigation water storage tanks.

The preliminary opinion of construction cost for this project is \$3.7 million.

It is estimated that the new water treatment plant could be operational as soon as 18 months after authorization to begin design and permitting.

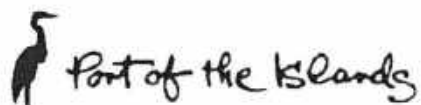

## **BACKGROUND**

Port of the Islands Community Improvement District provides the local governmental services for the Port of the Islands planned community, located in southern Collier County. Refer to Figure 1-1 for a location map. The Port of the Islands Community Improvement District was established in 1990 with each parcel of land assigned a number of Equivalent Residential Connections (ERC) in proportion to their share of Bond debt to be paid through tax assessments. In this manner, the build-out demand for utilities can be identified. During the first ten to twelve years, development was at a fairly steady, although slow pace. Then during the next few years the rate of development increased before slowing down with the current downturn in the national economy.

The community consists of two hotels, a 174 slip marina, 165 single family lots, Collier County approvals for 644 multifamily units, and undeveloped property with approximately 220 Utility ERCs. The community, including layout of the existing potable water and fire/irrigation water system, is identified in the attached aerial photograph exhibits. Each Utility ERC is equivalent to a single family residence. The south hotel currently is configured with 86 condominium units and the north hotel consists of 100 standard hotel rooms. At the time the CID was established, the north hotel and conference center (89 ERCs) was identified as having dining and meeting facilities to serve up to 400 people, although occupancy during the past fifteen years has been very limited. The bulk of the remaining undeveloped property is located either north of the north hotel (183 ERCs) or the commercial properties along US 41 at Newport Drive and Cays Drive (28 ERCs). Redevelopment of the south hotel property has been approved by Collier County for 90 multifamily units and redevelopment of the north hotel property is also a potential at some point in the future.

It is estimated that 109 of the 165 single family lots have houses constructed at this time (66%) and that 510 of the County approved 644 multifamily units have been constructed at this time (70%). The following summarizes the status of development in these residential areas which have been developed.

The Cays – Phase I (west side)	59 out of 75 single family lots
The Cays – Phase II (east side)	50 out of 90 single family lots
Sunset Cay/Sunset Cay Lakes	192 out of 192 multifamily units
Sunrise Cay	68 out of 68 multifamily units
Stella Maris	134 out of 134 multifamily units
Orchid Cove	116 out of 160 multifamily units
The Retreat del Sol	0 out of 90 multifamily units

With regard to utility ERCs, there are 517 ERCs constructed out of 680 ERCs associated with the identified uses in these areas of the community.

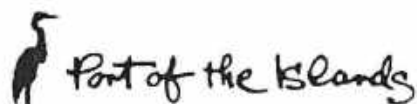

**PRELIMINARY ENGINEERING REPORT**  
**PORT OF THE ISLANDS WATER TREATMENT PLANT**  
June 10, 2009  
Page 4

Constructed Units

Single Family	109 units x 1 ERC/SF unit	= 109 ERC
Multifamily	<u>510 units</u> x 0.8 ERC/MF unit	= <u>408 ERC</u>
Total constructed	619 units	= 517 ERC

Planned Units in these developments

Single Family	165 units x 1 ERC/SF unit	= 165 ERC
Multifamily	<u>644 units</u> x 0.8 ERC/MF unit	= <u>515 ERC</u>
Total planned in these areas	809 units	= 680 ERC

The total number of utility ERCs for the entire community is 1,032, so the ERCs associated with the housing units already constructed in these areas of the community represent one-half of the total utility ERCs planned for the entire community. The ERCs allocated to other properties, not identified above, is the difference between 1,032 and 680 or 352 ERCs. The bulk of these ERCs are allocated to the North Hotel and former RV Park properties (89 ERCs and 183 ERCs respectively). These properties are zoned RT by Collier County and could be developed at a density as high as 16 units per acre which is appropriate for a resort hotel or other high density multifamily development. The maximum development of these properties, as are all properties at Port of the Islands, is limited by the available ERCs allocated to each property. For purposes of estimating equivalent build-out population, the 352 ERCs which were not identified above with the existing residential properties are converted to the number of potential multifamily units using the ratio of 0.8 ERCs per multifamily unit resulting in the potential of an additional 440 multifamily units if all of these ERCs were converted to multifamily use. Adding the 809 housing units in the planned (and mostly developed) portions of the community to the potential for an additional 440 multifamily units (or equivalent) yields a total of 1,249 housing units at build-out. Using a ratio of 2.0 persons per housing unit multiplied times the number of potential housing units at build-out suggests a build-out population of 2,500 persons.

Presently, due to current economic conditions, a number of the completed housing units at Port of the Islands either remain the property of their developer or are unoccupied and listed for sale. The occupancy rates at the two hotels are also rather low. It is estimated that today the equivalent population for the community is approximately 1,000 persons. Therefore, it is believed that future demand for potable water will be approximately 2.5 times greater than it has been in recent years.

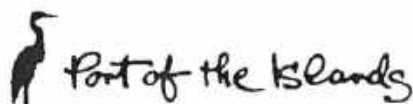

**PRELIMINARY ENGINEERING REPORT**  
**PORT OF THE ISLANDS WATER TREATMENT PLANT**  
June 10, 2009  
Page 5

The Port of the Islands Community Improvement District owns and operates the existing lime softening water treatment plant, located in the northeast quadrant near the end of Union Road. This water treatment plant was purchased more than 15 years ago when a private utility company which previously operated in northern Collier County connected to the Collier County Utilities water system and declared it surplus. The existing water treatment plant is more than 30 years old and has reached its useful life. Water treatment technology has progressed since this water treatment plant was new and the existing lime softening treatment technology does not remove as much naturally occurring organic matter as the new treatment technologies. It is becoming more and more difficult to be able to repair the corroded steel tank components and some of these areas with corroded metal are getting to the point of structural concern in addition to tank leaks. Recent sanitary survey performed by the Florida Department of Environmental Protection (FDEP) has confirmed the condition of this water treatment plant and has indicated a number of substantial improvements be made or that a new water treatment plant be constructed (a copy of the May 13, 2009 FDEP report is provided in the Appendix). A new water treatment plant has been contemplated for the community and has been included in the CID's capital improvement plan for the past four to five years, although a project initiation date was not yet established.

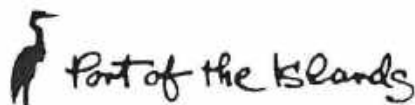



### **WATER RESOURCE EVALUATION**

The current water supply source is two wells located approximately two miles northeast of the water treatment plant. These wells draw water from the Lower Tamiami aquifer with the large wetland areas north and east of the wells as the general recharge area. The naturally occurring organic matter in the well water is a natural byproduct of decomposition in the surficial layer of soil in the wetland areas surrounding the wells and recharging the aquifer in this area. The water quality is fresh in this area of fairly rapid recharge with essentially no competing users. The water quality is influenced by the Fakha Union Canal and its connection to the Gulf of Mexico and as a result the water from the surficial aquifer has higher salinity as you move west from the existing wells toward the Fakha Union Canal.

During February and March of 2008, a testing program was performed at Port of the Islands in both the vicinity of the existing water treatment plant and existing wellfield. It was determined that the water table aquifer in the vicinity of the water treatment plant, although it contained fresh water, consisted of low permeability sands which limit yield making it unsuitable for either potable or irrigation water supply. The Lower Tamiami aquifer (aquifer immediately below the water table aquifer) is highly productive near the water treatment plant site, although it contains chlorides at approximately 3,800 mg/l making it unsuitable irrigation water supply and only suitable for potable water supply if treated to remove the dissolved minerals and salts. It was determined that in the vicinity of the existing wellfield that the Lower Tamiami aquifer exists between a depth of approximately 15 feet and 80 feet below land surface (BLS) with chlorides ranging from 80 mg/l at 30 feet BLS to 1,200 mg/l at 80 feet BLS.

Computer model simulations identified that pumping 0.832 MGD (maximum permitted flow for potable water and irrigation water combined) from the two existing wells would be expected to result in a drawdown of approximately 0.5 feet in the water table aquifer which is deemed a minimal impact on neighboring wetlands. Additional computer modeling was performed to assess the potential for upconing (movement of chlorides from below the bottom of the well up into the well). This modeling indicated that after 20 years of continuous pumping at 0.532 MGD (average annual permitted flow for potable water and irrigation water combined) that the chlorides would be expected to increase from 80 mg/l to 200 mg/l. (The chloride limit for potable water is 250 mg/l so an increase to 200 mg/l is not considered a problem, especially since water treatment technology being considered will remove a significant amount of chloride.) In order to minimize the potential for upconing it was recommended that a third well be constructed and each well be limited to a maximum flow of 200 gpm. The test well was recommended to be converted to a monitoring well to be used for observing the conditions in the POI wellfield and that the third well be constructed near the northwest corner of Section 2 (R28E, T52S). Refer to Figure 2-1 from the November 2008 application to modify the SFWMD water use permit.

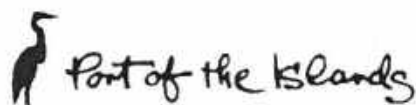



**INVESTIGATION OF DESIGN CAPACITY NEEDED**

Port of the Islands Community Improvement District submitted an application to the SFWMD in 2005 for renewal of their Water Use Permit for public water supply. Table F from that application provided a summary of historic water use for the period 1998 thru 2004 and is provided in Exhibit 1.

Exhibit 1 – Past Water Use data submitted to SFWMD in 2005

**TABLE F**  
**Past Water Use**

Year	Past Population*	Per Capita Usage	Total Annual Use (MG)	Average Month Use (MG)	Maximum Month Use (MG)	Ratio Max:Average
1998	590	116	25.0	2.05	2.90	1.41
1999	625	120	27.4	2.25	3.00	1.33
2000	675	116	28.6	2.35	3.10	1.32
2001	735	104	28.0	2.30	3.20	1.39
2002	790	102	29.5	2.43	3.35	1.38
2003	840	100	30.7	2.52	3.55	1.41
2004	885	106	34.3	2.82	3.80	1.35

\* Source of Projected Population Information: Number of ERC constructed, 2.0 persons per ERC.

Table G from that application provided a projection of growth within the community for the period 2005 thru 2014 and is provided in Exhibit 2. In developing these population projections, it was assumed that the community would be built out in 2014 at an equivalent population of 2,650 persons. The permit was issued on August 31, 2006 (expiration date of September 8, 2016) for an annual withdrawal of 111.2338 million gallons and a maximum month withdrawal of 12.9702 million gallons. The permitted annual average daily flow is equal to 304,750 gallons per day while the permitted maximum month average daily flow is equal to 432,000 gallons per day (potable water only). The flows allowed by the 2006 permit were essentially what were requested in the 2005 permit application and were similar to the amount which had been previously approved by the SFWMD for this community.

Exhibit 2 – Projected Water Use data submitted to SFWMD in 2005

**TABLE G**  
**Projected Water Use**

Year	Projected Population*	Per Capita Usage	Total Annual Use (MG)	Average Month Use (MG)	Maximum Month Use (MG)	Ratio Max:Average
2005	1060	115	44.5	3.71	5.19	1.40
2006	1235	115	51.8	4.32	6.05	1.40
2007	1410	115	59.2	4.93	6.90	1.40
2008	1585	115	66.5	5.54	7.76	1.40
2009	1760	115	73.9	6.16	8.62	1.40
2010	1935	115	81.2	6.77	9.48	1.40
2011	2110	115	88.6	7.38	10.33	1.40
2012	2285	115	95.9	7.99	11.19	1.40
2013	2460	115	103.3	8.60	12.05	1.40
2014	2650	115	111.2	9.27	12.98	1.40

\* Source of Projected Population Information: Buildout to approved zoning densities within 10 yr.

[sfwmd.gov](http://sfwmd.gov)

Exhibit 3 – Graphical Representation of Flow data used in 2005 WUP Application

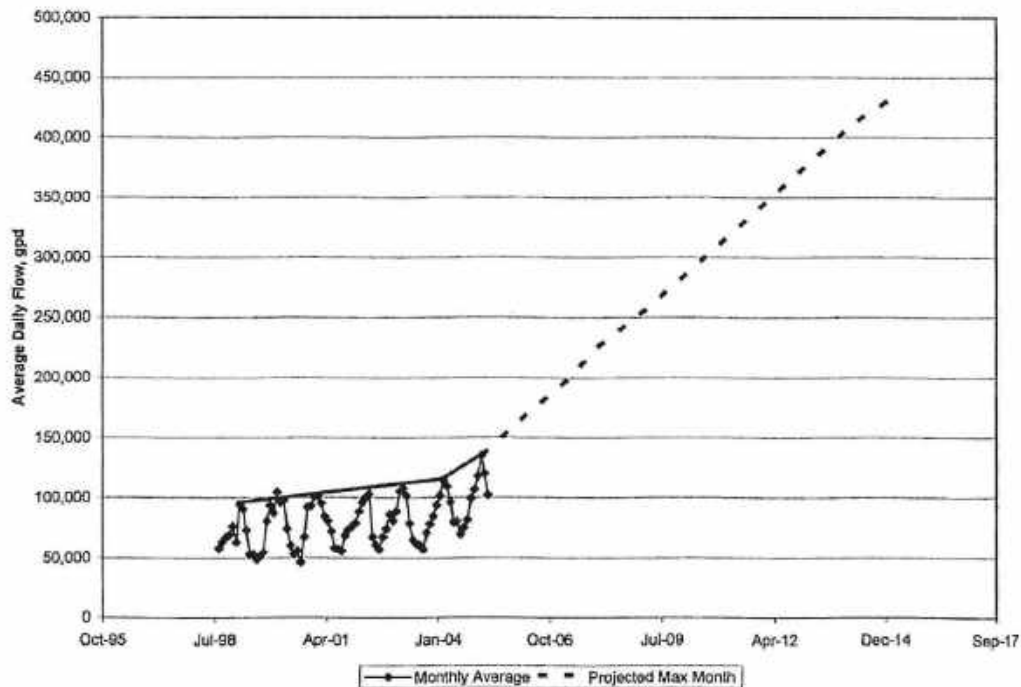

**PRELIMINARY ENGINEERING REPORT**  
**PORT OF THE ISLANDS WATER TREATMENT PLANT**  
 June 10, 2009  
 Page 9

Exhibit 3 illustrates the monthly flow data which was used in preparation of the Water Use Permit along with the actual maximum month flow data and projected maximum monthly flow data. A couple key items related to the justification for build-out water demand was: (1) population estimates based on number of meter connections suggested an annual average daily flow of 115 gallons per capita per day and maximum month average daily flow of 160 gallons per capita per day (gpcd), (2) the rate of development was speeding up along with a corresponding increase in water consumption, and (3) the build-out population in 2014 was estimated to be three times greater than the 2004 estimated population.

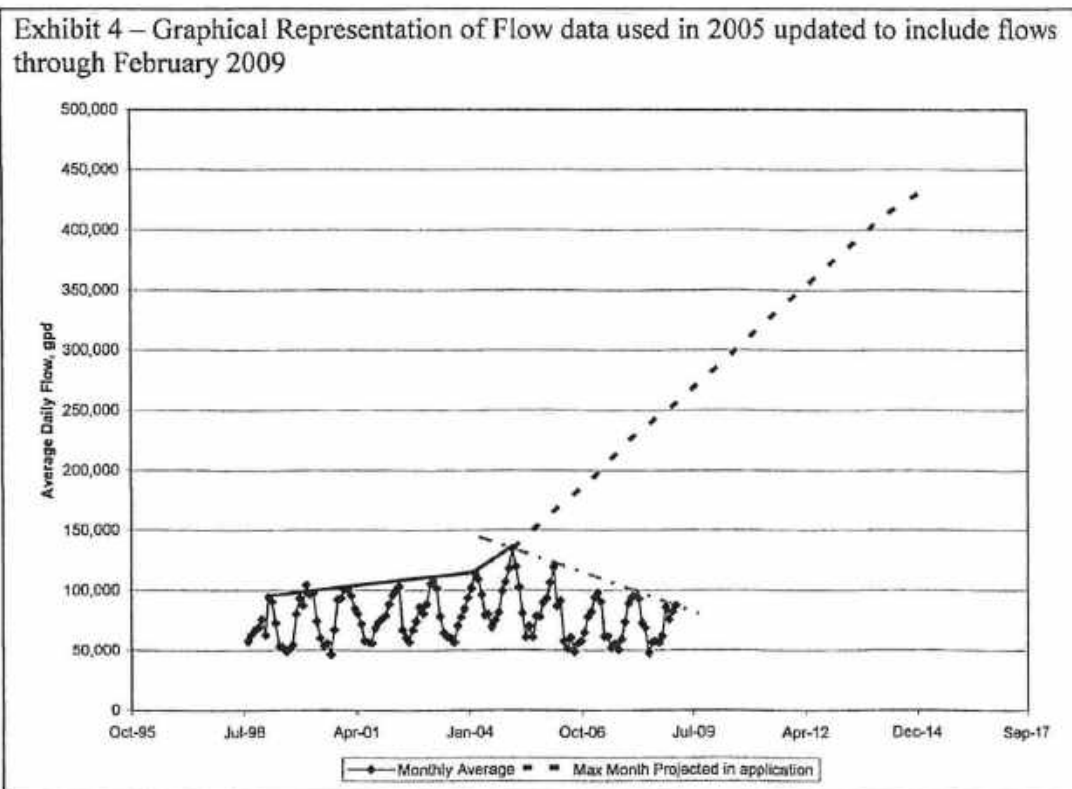

These 2005 data have been updated with the actual flows during the past three and one-half years and are provided here as Exhibit 4. The historic flows for the period 2005 through present suggest a steady decline in maximum monthly flows. It is believed that there are four primary reasons for the decline in flow instead of the projected increase in flow: (1) the irrigation system and fire hydrants located in the first phase of The Cays (Newport Cay and Morningstar Cay) were converted to the fire and irrigation system which would have shifted demand from the potable water system to the irrigation system, (2) the slowdown in the real estate market has resulted in failure to attract new occupants

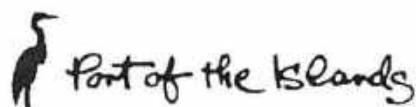

to many of the multifamily units which were constructed, (3) many of the existing housing units, especially those used seasonally, appear to not be occupied at historic rates, and (4) more attention has been paid to identifying un-accounted for water resulting in less water needing to be produced to meet community needs.

The SFWMD has requested an update of the historic flow and population data for preparing an update in projection of future withdrawals for potable water at Port of the Islands. The updated Table F is provided here in Exhibit 5. The average per capita usage for the past five years is approximately 90 gpcd, even using the average for the past couple of years which have likely been impacted by the high percentage of unoccupied housing units which are currently For Sale.

Exhibit 5 – Updated Table F to include data through 2008

**TABLE F**  
**Past Water Use**

Year	Past Population*	Per Capita Usage	Total Annual Use (MG)	Average Month Use (MG)	Maximum Month Use (MG)	Ratio Max:Average
1999	590	116	25.0	2.05	2.90	1.41
2000	625	120	27.4	2.25	3.00	1.33
2001	675	116	28.6	2.35	3.10	1.32
2002	735	104	28.0	2.30	3.20	1.39
2003	790	102	29.5	2.43	3.35	1.38
2004	840	100	30.7	2.52	3.55	1.41
2005	885	106	34.3	2.82	3.80	1.35
2006	910	90	29.8	2.48	3.34	1.35
2007	935	76	25.8	2.15	3.03	1.41
2008	960	74	26.0	2.17	2.92	1.35

\* Source of Projected Population Information: Number of ERC Constructed, 2.0 persons per ERC.

It is proposed to use 90 gpcd for the annual average per capita usage, in place of the previously used 115 gpcd (2005 permit application) to account for shifting of some demand on the potable system for the remaining portions of the community which were still using potable water for irrigation at that time, as well as some reduction in lost water. It is assumed that the proposed water treatment plant will be a nanofiltration type process with a recovery of approximately 85 percent of the raw water processed into finished water. Therefore, in order to produce 90 gpcd the new water treatment plant will require 106 gpcd of raw water. Using the projected build-out population of 2,500 persons, and an annual average per capita demand of 106 gpcd, results in a build-out water demand of 265,000 gpd. Using the historic ratio of maximum month to annual average demands of 1.40, results in a projected maximum monthly average daily requirement for raw water of 370,000 gpd.

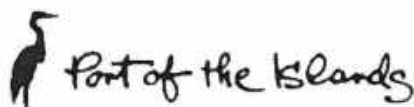

**PRELIMINARY ENGINEERING REPORT**  
**PORT OF THE ISLANDS WATER TREATMENT PLANT**  
June 10, 2009  
Page 11

While the SFWMD permits water withdrawals based on maximum monthly flow and annual flow, water treatment plants are permitted by FDEP based on a maximum daily flow of water produced. Recall that a recovery of 85 percent of the raw water resulting in finished water was used previously. Historically, a ratio of between 1.3 and 1.5 has been typical when comparing maximum daily flow to maximum month average daily flow for the Port of the Islands system. The maximum daily flow of raw water can be estimated to be 500,000 gpd using a maximum day peak factor of 1.35 times larger than the maximum monthly average daily flow along with the projected 370,000 gpd maximum month average daily flow. This needs to be reduced to 85 percent to account for finished water produced.

Projected Build-out Annual Average Daily Flow	0.225 MGD
Projected Build-out Maximum Month Average Daily Flow	0.315 MGD
Projected Build-out Maximum Daily Flow	0.425 MGD

As a comparison, the actual flows during the most recent twelve month period were:

Annual Average Daily Flow (Mar 2008-Feb 2009)	0.070 MGD
Maximum Month Average Daily Flow (Mar 2008)	0.093 MGD
Maximum Daily Flow (Mar 2008)	0.130 MGD

Another point of comparison is the maximum recorded flow conditions for this facility:

Annual Average Daily Flow (Apr 2004-Mar 2005)	0.098 MGD
Maximum Month Average Daily Flow (Feb 2005)	0.135 MGD
Maximum Daily Flow (Feb 2005)	0.175 MGD

Another factor to be considered when doing an evaluation to determine the design capacity for a new water treatment plant is the probability of the projected build-out flow being reached. A good way to consider this when reviewing the above calculation based on projecting raw water needs is to recognize that in the current permitting situation which exists for existing permitted users in the vicinity of Port of the Islands is that any water not allocated to an existing user will be reserved for the environment and not available for allocation in the future for potable water or irrigation uses. This requires that projection of future water needs be done at a very high percentile of potential need as correction of the projection to obtain a higher allocation at some time in the future will be extremely difficult. On the other hand, in the event that not all of the allocation is needed in the future there is limited, if no, downside. With regard to the water treatment plant, it is preferred to use the above numbers for what they represent – the maximum projected need at some time in the future. Therefore, the proposed water treatment plant needs to be designed to possibly produce the above indicated demands although it will be preferred to install only a portion of the maximum equipment needs at the time of construction while allowing it to be easy to install additional equipment in the future. There are several reasons for this including: (1) to limit initial expenditure to units with a

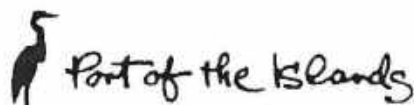

**PRELIMINARY ENGINEERING REPORT**  
**PORT OF THE ISLANDS WATER TREATMENT PLANT**  
June 10, 2009  
Page 12

high probability that they will be needed, and (2) to not install equipment so far in advance of their need such that limited hours of use would be likely prior to equipment eventually requiring replacement due to corrosion or becoming outdated prior to wearing out. Expansion of the type of membrane treatment plant which is envisioned is fairly easy if sufficient physical space and pipeline stub-outs are left for future expansion of the water treatment plant allowing for future installation of additional membrane skid(s) in a modular fashion.

It is suggested that an initial capacity of approximately 200 percent of the maximum flow treated at this facility during the past 12 months be used for design purposes with room provided in the design for additional pumping and membrane equipment to expand the facility up to the maximum allowed under the raw water allocation. Therefore the following initial finished water production capacity is proposed.

Recommended Initial Annual Average Daily Flow	0.150 MGD
Recommended Initial Maximum Month Average Daily Flow	0.210 MGD
Recommended Initial Maximum Daily Flow	0.280 MGD

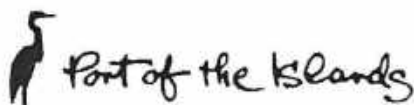



**OVERALL PLAN FOR WATER CONSERVATION AND REUSE**

The Port of the Island water, wastewater, and irrigation systems will be tied together to allow for reuse of all water possible prior to use of the combination of raw water from the wells along with reclaimed water generated at the proposed membrane WTP and produced at the existing membrane bioreactor (MBR) WWTP. An example of the anticipated water balance at initial construction phase maximum month average daily flows is provided in Exhibit 6.

Two out of the three surficial aquifer wells will operate simultaneously with approximately one-half of the raw water from the wellfield going to the membrane WTP and one-half going directly into the Reclaimed Water Storage Tank. As the raw water passes through the NF membranes approximately 85% becomes finished water and 15% will contain the concentrated dissolved solids removed from the raw water. The Concentrate flow will be discharged into the Reclaimed Water Storage Tank. The finished water will be provided to the potable water system customers and approximately two-thirds of the volume will be returned to the sanitary sewer system following use by the customers and transported to the WWTP. The wastewater will be treated by the MBR and disinfected using chlorine prior to discharge into the Reclaimed Water Storage Tank. Approximately 8 percent of the water used for irrigation will have been reclaimed from the NF membrane concentrate (which would otherwise have needed proper disposal) and approximately 28 percent will have been reclaimed from the WWTP effluent (which would otherwise have been disposed into the wetland system). As a result, only approximately 64% of irrigation needs will have been met using raw water from the wellfield.



**PRELIMINARY ENGINEERING REPORT**  
**PORT OF THE ISLANDS WATER TREATMENT PLANT**  
 June 10, 2009  
 Page 14

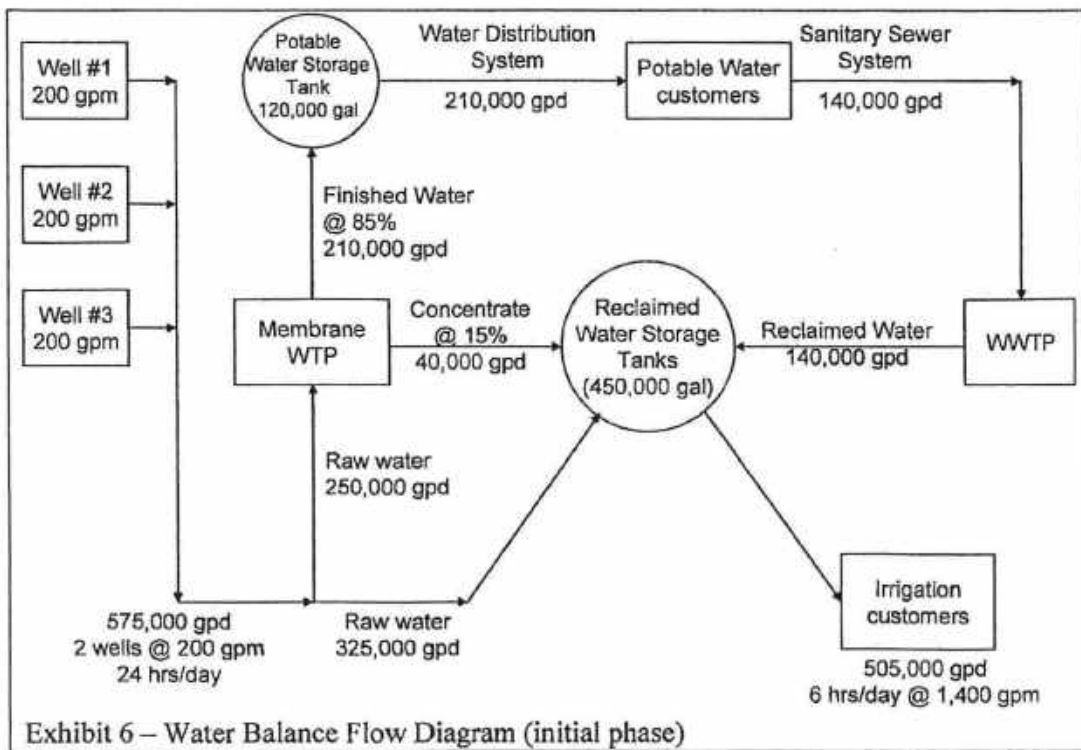
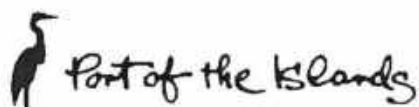
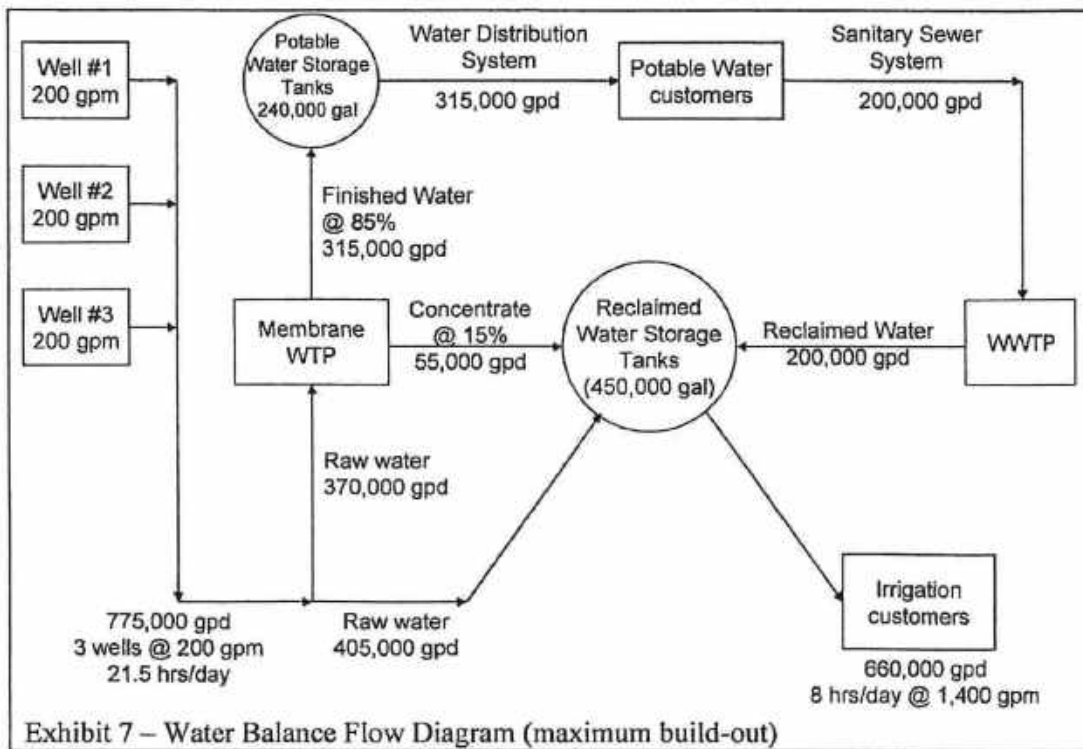

Exhibit 7 provides the water balance for build-out flow conditions. In the event potable water demands were to reach this level it is anticipated that an additional potable water storage tank may be needed. If irrigation demands reach this level, an additional reclaimed water storage tank may be needed also.





**RAW WATER QUALITY**

Samples were collected of the raw water from the POI wellfield and sent to a water quality testing laboratory in order to obtain information to be used in the preliminary analysis of the proposed water treatment system. The results of this testing for conventional water quality parameters are summarized below. In addition, the raw water was tested for a wide spectrum of potential pollutants and found to not have any amounts of these potential pollutants at levels which can be detected. Copies of laboratory testing reports are included in the Appendix.

Sample Event Raw Water Well #2 (West Well) March 25, 2009

PARAMETER	RESULT	UNITS
Sodium	34	mg/L
Barium	0.021	mg/L
Sulfate	36	mg/L
Chloride	69	mg/L
Fluoride	0.01	mg/L
Total Dissolved Solids	404	mg/L
Iron, total (Fe)	0.66	mg/L
Manganese (Mn)	0.025	mg/L
Color	15	C.U.
Arsenic	0.0026	mg/L

Additional analyses performed on sample collected April 22, 2009

PARAMETER	RESULT	UNITS
Calcium (Ca)	120	mg/L
Magnesium (Mg)	4.7	mg/L
Potassium (K)	0.79	mg/L
Ammonium (NH <sub>4</sub> )	0.19	mg/L as N
Strontium (Sr)	0.23	mg/L
Bicarbonate (HCO <sub>3</sub> ) Alkalinity	293	mg/l as CaCO <sub>3</sub>
Carbonate (CO <sub>3</sub> ) Alkalinity	1.29	mg/l as CaCO <sub>3</sub>
Hydroxide (OH) Alkalinity	0.02	mg/l as CaCO <sub>3</sub>
Phosphate (PO <sub>4</sub> )	0.010	mg/L as P
Dissolved Silica (SiO <sub>2</sub> )	4.6	mg/L
Total Silica (SiO <sub>2</sub> )	5.2	mg/L
Total Hardness	332	mg/l as CaCO <sub>3</sub>
Carbon Dioxide (CO <sub>2</sub> )	258	mg/L
TOC	3.1	mg/L

**PRELIMINARY ENGINEERING REPORT**  
**PORT OF THE ISLANDS WATER TREATMENT PLANT**  
June 10, 2009  
Page 17

Field Sample Event Raw Water Well #2 (West Well) April 20, 2009

PARAMETER	RESULT	UNITS
Conductivity	751	micromho/cm $\mu$ s/cm
pH	6.87	Standard Units
Turbidity	0.05	NTU
Temperature	75.38	degrees, Fahrenheit

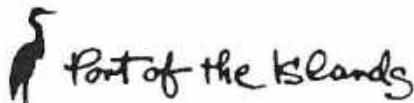

## **ALTERNATIVES**

### Water Supply Alternatives

There are two water supply alternatives. One is to continue to use the water from the Lower Tamiami aquifer supplied from the two existing shallow wells (plus one additional well identified in recent permit modification application submitted to SFWMD). The other water supply alternative is to drill new water supply wells in the vicinity of the water treatment plant. Computer modeling of the existing wells indicate that these wells are envisioned to remain at acceptable chloride concentrations for the foreseeable future, although it is not anticipated that additional water supply (above permitted levels) would be able to be obtained in the future due to recent regulations regarding reservation of available water for the environment. Under the first alternative, the existing wells will supply irrigation water demands (in excess of production of reclaimed water) in addition to supplying raw water for the water treatment plant. Under the second alternative, the existing wells would only need to meet irrigation demands, both on a quantity and quality basis.

### Water Treatment Alternatives

The water treatment alternatives can generally be tied to the water supply alternatives.

In the event that the existing wells are retained for potable water production then a water treatment process will be needed which can remove the hardness from the well water as well as provide sufficient removal of THM precursors (naturally occurring organic matter). Where, in the past the use of lime softening (similar to what is presently being done at Port of the Islands) was the most common treatment method for raw water of this quality, at this time it is much more common to use a membrane treatment method for raw water of this quality as the membrane process also removes THM precursors and provides a higher level of protection from potential biological contaminants such as viruses, Giardia, and Cryptosporidium. The Collier County North Regional Water Treatment Plant uses membrane softening to treat water from the Lower Tamiami Aquifer (approximately 100 feet deep) obtained from wells located in eastern Golden Gate Estates. The same water supplied from these wells is also treated at the older Collier County South Regional Water Treatment Plant (SRWTP) using lime softening. During recent years when the SRWTP was expanded it was done by constructing a new membrane treatment facility on the site of the lime softening plant. Another local example is the Golden Gate Utilities water treatment plant where the original water treatment plant was lime softening and when this facility was expanded a new membrane softening plant was constructed on the same site treating the same source water. In both of these cases, the existing lime softening plant was not abandoned although the new facility treating the same source water was constructed using membrane technology. In addition, once the lime softening plant reaches its useful life at these facilities it is envisioned that it will eventually be replaced with a new membrane treatment facility.

In the event that new brackish water wells were to be used for the source water, a desalination water treatment system would be needed to remove the chlorides and other dissolved minerals and salts from the water. Methods of desalination include distillation, electrodialysis, and reverse osmosis. Distillation is not an efficient method of desalination for brackish due to relatively low salinity of the water being treated and the resulting very high energy costs. Electrodialysis and Electrodialysis/Reversal, although previously used in brackish water treatment in southwest Florida, are not currently being used. Improvements to membrane technology and relative costs of reverse osmosis in today's market have generally made membrane treatment the choice for new water treatment plants in Florida. Reverse osmosis has become the most common method of treating brackish water as the relative cost of the membranes has come down and also because it has the least power cost of the desalination options. As Collier County maximized the potential use of the water supply available in eastern Golden Gate Estates they moved toward brackish water supply and reverse osmosis treatment. The newer water treatment plant for Collier County (also physically located at the South Regional Water Treatment Plant) is a reverse osmosis treatment plant with brackish source water supply. Similarly, the City of Naples has recently developed a master plan for water resources and treatment which identifies continued use of their existing fresh water wells using the existing lime softening treatment plant while identifying construction of future brackish water wells along with reverse osmosis treatment once the supply of freshwater has been exhausted.

#### Alternatives for Consideration

Alternative One consists of continuing to use the existing wells as the source water and to treat it using membrane technology (either nanofiltration or Reverse Osmosis). Membrane treatment of water (either fresh or brackish) results in what is called concentrate or reject water. The concentrate essentially has almost all of the dissolved materials originally in the raw water, while the product water has a much lower concentration of these materials than the raw water. In treating the raw water from the existing wellfield, the resulting concentrate will be able to be recovered for irrigation supply after blending with a combination of reclaimed wastewater effluent and raw water. Therefore, essentially 100 percent of the raw water will be used and no waste byproduct produced which would require disposal.

Alternative Two consists of drilling new brackish water wells near the water treatment plant for the source water and to treat it using reverse osmosis. Reverse Osmosis treatment of brackish water also results in a concentrate, although since the raw water is much higher in dissolved materials the concentrate which is produced is very high in these materials and cannot be recovered for irrigation supply. The concentrate produced would require disposal and the only practical disposal method in this area would be deep injection. A deep injection well of the type required is very expensive to permit and construct. The costs for permitting and constructing of deep injection wells have a very



large minimum cost even for small facilities such as the proposed Port of the Islands WTP. A deep injection well for this project could easily cost as much as the cost of the proposed water treatment plant resulting in a doubling of the overall project cost. Brackish water treatment using Reverse Osmosis is more practical for larger facilities where the cost of deep injection disposal of concentrate can be allocated against a much larger production capacity.

#### Consideration of Number of Membrane Modules to Install

As described previously in this report, the ultimate maximum day design capacity for this facility has been identified as 425,000 gallons per day (gpd). As this capacity is more than three times greater than the maximum daily flow at the WTP during the past twelve months (130,000 gpd), it is suggested that an interim design flow of 280,000 gpd should be considered. The membrane treatment system is anticipated to produce finished water at 80% of the feed rate with the other 20% being blended with raw water and reclaimed wastewater effluent for irrigation use. The wells have a production limit, to minimize salt water intrusion, of 200 gpm each and there will be a total of three wells to supply raw water for both potable water use as well as irrigation. It appears that two options should be considered: (1) one membrane skid for each well, or (2) two membrane skids for each well. The reason for this consideration is that if one membrane skid is assigned to each well that in the event that one skid were down for repair or maintenance then a large percentage of the treatment capacity is unavailable. For example if two skids were installed and one was offline then 50% of the treatment capacity would be unavailable. The way to overcome this would be to provide a third (spare) membrane skid. Alternatively, if four skids were installed such that two skids provide treatment for the water supplied by each well then if one skid was offline for repair or maintenance then the other three skids would be able to provide 75% of the treatment capacity of the facility. This would likely be sufficient as the facility could be operated a few extra hours during the day to overcome this short-term reduction in capacity, whereas the other option would require operating twice as many hours and this might be a problem on a practical basis.

#### Option One

This option includes design of the membrane treatment units in increments of 100 gpm of feedwater each to allow two membrane skids to effectively handle the water from each well. Initially, the wellfield will be operated with only two of the three well pumps in operation simultaneously for a combined feedwater flow of 400 gpm. Therefore four membrane skids would be needed initially. Four membrane skids would produce a total of 320 gpm of product water. It would take 14.5 hours per day when operating with two wells in service and with four membrane skids in service to produce the maximum daily flow of 280,000 gpd. During peak season, to produce the average daily flow anticipated during the highest 30 day period each year, it would take an average of 11 hours per day

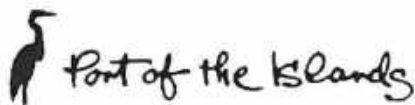

**PRELIMINARY ENGINEERING REPORT**  
**PORT OF THE ISLANDS WATER TREATMENT PLANT**  
June 10, 2009  
Page 21

to produce the maximum month average daily flow of 210,000 gpd. During the remainder of the year, four membrane skids would operate an average of 8 hours per day in order to produce the average annual daily flow of 150,000 gpd. During the first few years of operation, it is anticipated that the membranes would only need to be operated 8 hours per day to meet maximum daily flow needs and most days would operate less than 8 hours per day.

At such time in the future, when the water production needs may reach as high as 425,000 gpd, the well pumps would require upgrades to allow all three wells to operate simultaneously at a maximum combined flow rate of 600 gpm in order to supply sufficient water for both potable water needs and to supplement irrigation water needs. At that time there are two alternatives for meeting potable water production needs: (1) operate the four membrane skids using water from two wells for additional hours each day, or (2) to install two additional membrane skids in order to treat the additional raw water available from a total of three wells. The anticipated operating conditions under each of these scenarios are summarized below.

Four membrane skids operating together would be expected to produce 320 gpm from 400 gpm of feed water. It would take 22 hours per day when operating with two wells in service and with four membrane skids in service to produce the ultimate maximum daily flow of 425,000 gpd. During the maximum month demand period, it would take 16.5 hours per day to produce the maximum month average daily flow of 315,000 gpd. During the remainder of the year, four membrane skids would operate an average of 12 hours per day in order to produce the average annual daily flow of 225,000 gpd.

Six membrane skids operating together would be expected to produce 480 gpm from 600 gpm of feed water. It would take 15 hours per day when operating with three wells in service and with six membrane skids in service to produce the ultimate maximum daily flow of 425,000 gpd. During the maximum month demand period, it would take 11 hours per day to produce the maximum month average daily flow of 315,000 gpd. During the remainder of the year, four membrane skids would operate an average of 8 hours per day in order to produce the average annual daily flow of 225,000 gpd.

In order to accommodate this option, the new water treatment plant building would be designed to accommodate six membrane skids, each with a feedwater capacity of 100 gpm and production capacity of 80 gpm. In this manner, the CID will have the option of installing additional equipment at some point in the future in the event the potable water demands were to reach the ultimate design capacity envisioned for the community and it was decided that they did not want to operate the water treatment plant more than 16 hours per day during peak season. Initial

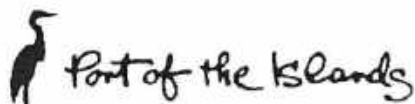

installation of four membrane skids will allow for meeting an initial maximum month flow more than two times larger than experienced during the past twelve months with operation of the membranes for 11 or 12 hours per day. Although initially the treatment plant could be operated with less than four membrane skids in service if operated for more hours each day, it does not appear to be advisable to install less than four skids as there is a requirement to have a minimum level of system redundancy in the event of equipment being out of service for repair. In addition, it is also likely that the potential deferment of expenditure for membranes would more than be offset by the additional operating costs required to operate the facility for additional hours each day.

#### Option Two

This option includes design of the membrane treatment units in increments of 200 gpm of feedwater each to allow a single membrane skid to effectively handle the water from each well. Initially, the wellfield will be operated with only two of the three well pumps in operation simultaneously for a combined feedwater flow of 400 gpm. Therefore two membrane skids would be needed initially. Two membrane skids would produce a total of 320 gpm of product water. It would take 14.5 hours per day when operating with two wells in service and with two membrane skids in service to produce the maximum daily flow of 280,000 gpd. During peak season, to produce the average daily flow anticipated during the highest 30 day period each year, it would take an average of 11 hours per day to produce the maximum month average daily flow of 210,000 gpd. During the remainder of the year, two membrane skids would operate an average of 8 hours per day in order to produce the average annual daily flow of 150,000 gpd. During the first few years of operation, it is anticipated that the membranes would only need to be operated 8 hours per day to meet maximum daily flow needs and most days would operate less than 8 hours per day.

At such time in the future, when the water production needs may reach as high as 425,000 gpd, the well pumps would require upgrades to allow all three wells to operate simultaneously at a maximum combined flow rate of 600 gpm in order to supply sufficient water for both potable water needs and to supplement irrigation water needs. At that time there are two alternatives for meeting potable water production needs: (1) operate the two membrane skids using water from two wells for additional hours each day, or (2) to install an additional membrane skid in order to treat the additional raw water available from a total of three wells. The anticipated operating conditions under each of these scenarios are summarized below.

Two membrane skids operating together would be expected to produce 320 gpm from 400 gpm of feed water. It would take 22 hours per day when operating with two wells in service and with two membrane skids in service to produce the ultimate maximum daily flow of 425,000 gpd. During the maximum month demand period, it would take 16.5 hours per

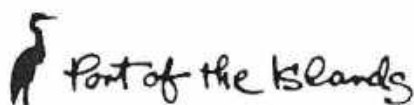

day to produce the maximum month average daily flow of 315,000 gpd. During the remainder of the year, two membrane skids would operate an average of 12 hours per day in order to produce the average annual daily flow of 225,000 gpd.

Three membrane skids operating together would be expected to produce 480 gpm from 600 gpm of feed water. It would take 15 hours per day when operating with three wells in service and with three membrane skids in service to produce the ultimate maximum daily flow of 425,000 gpd. During the maximum month demand period, it would take 11 hours per day to produce the maximum month average daily flow of 315,000 gpd. During the remainder of the year, two membrane skids would operate an average of 8 hours per day in order to produce the average annual daily flow of 225,000 gpd.

In order to accommodate this option, the new water treatment plant building would be designed to accommodate four membrane skids, each with a feedwater capacity of 200 gpm and production capacity of 160 gpm. In this manner, the CID will have the option of installing three membrane skids initially with a fourth membrane skid at some point in the future in the event the potable water demands were to reach the ultimate design capacity envisioned for the community and it was decided that they did not want to operate the water treatment plant more than 16 hours per day during peak season. Initial installation of three membrane skids will allow for meeting an initial maximum month flow more than two times larger than experienced during the past twelve months with operation of the membranes for 11 or 12 hours per day. Although initially the treatment plant could be operated with less membrane skids in service if operated for more hours each day, it does not appear to be advisable to install less than three skids as there is a requirement to have a minimum level of system redundancy in the event of equipment being out of service for repair. In addition, it is also likely that the potential deferment of expenditure for membranes would more than be offset by the additional operating costs required to operate the facility for additional hours each day.

#### Recommendation regarding number of Membrane Skids

The option of designing around 200 gpm membrane skids (one skid per well pump) results in the need to construct a smaller building for the same design capacity. The footprint for four 200 gpm skids is very similar to the footprint for four out of six 100 gpm skids that would be needed as an alternative. The equipment cost for four 200 gpm skids is similar to that for six 100 gpm skids due to trade off between reduction in number of feed pumps and associated piping and ancillary valves and fittings versus the higher cost for each unit with a larger capacity. An advantage of going with 200 gpm skids is the smaller size for the building as well as providing 100 percent of production

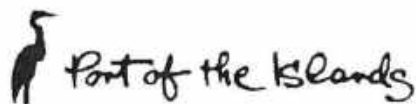

**PRELIMINARY ENGINEERING REPORT**  
**PORT OF THE ISLANDS WATER TREATMENT PLANT**  
June 10, 2009  
Page 24

capacity with one unit out of service (three out of four skids) versus 83.3 percent with one unit out of service (five out of six skids in service).

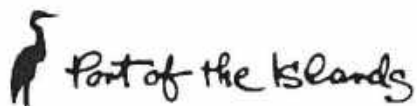



## **PRELIMINARY ENGINEERING**

Preliminary engineering design of the proposed POI water treatment plant has been performed to a level sufficient to allow preparation of a project budget and schedule and is provided in the attached exhibits.

Exhibit 1 provides a site plan for the existing POI utilities property and shows the likely location and size of the new WTP building. This is the same location and size of building which has been previously used for illustrative purposes when discussing ultimate development of the property currently owned by the CID and some adjacent parcels which the CID may consider acquiring. The building footprint which has been identified would meet the setbacks anticipated to be applied to this project by Collier County (note the WTP would be in the Conservation Zoning District and that the existing WTP was zoned as a Conditional Use in this Zoning District previously). This location will allow the new WTP to be closer in proximity to the WWTP, with the operations center/office for both facilities housed in the new building. Construction could proceed on the new WTP while the existing WTP remains in operation which would minimize disruption to the water system customers. Note that the proposed high service pumps are shown to be in a location between the existing water storage tank, proposed future water storage tank, and proposed water treatment building. This location would also allow the potential of this pump station to be constructed ahead of the WTP itself and to replace the existing pump station at the existing WTP in the event it were decided to replace the existing pump station instead of making the improvements noted by FDEP to the existing pump station and hydropneumatic tank. (This could allow spending money on a new facility which would fit into long-term needs instead of spending money on repairs to a facility which will be abandoned once the new WTP is built.)

Exhibit 2 provides a preliminary equipment layout for Option 1 (100 gpm skids). This exhibit shows that there is sufficient space available onsite for the WTP even if this arrangement of equipment (and phasing) was selected. This floor plan space allocation could serve as the starting point for facility detailed design and is not intended to show more than the concept to be applied for detailed design. Exhibit 3 provides the process flow diagram for Phase I if Option 1 were selected. Exhibit 4 provides the process flow diagram for Phase II if Option 1 were selected.

Exhibit 5 provides a preliminary equipment layout for Option 2 (200 gpm skids). This exhibit shows that Option 2 would require either a smaller building footprint (lower construction cost) or more room inside the building could be provided for other functions than that for Option 1. Exhibit 6 provides the process flow diagram for Phase I if Option 2 were selected. Exhibit 7 provides the process flow diagram for Phase I if Option 2 were selected and all available equipment were operated. Exhibit 8 provides the process flow diagram for Phase II if Option 2 were selected.

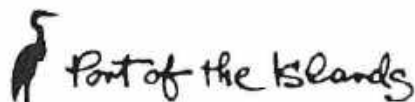



### TYPE OF MEMBRANES AND PRETREATMENT TO USE

After contacting three vendors and providing them with raw water quality data each vendor provided at least one treatment option using the equipment which they could provide. One principal difference between proposals is the type of membrane to use. The two types of membranes proposed for this raw water were either R.O. or nanofiltration. The primary difference between the two membrane types has to do with the size of the pores which the water passes during treatment. Nanofiltration membranes have larger pores and as such do not have as high pressure to pass the same volumetric flowrate of raw water, do not reject as much of the dissolved materials, and have a higher recovery rate (percentage of product water compared to raw water).

The following table provides a comparison between the raw water quality from the existing wells and the anticipated product water quality when treated using either reverse osmosis or nanofiltration. (This information is provided in order to show the relative levels of removal of minerals and salts and not for comparison between specific company's proposals as information was requested for both types of membranes to allow a comparison.) As can be seen from this table, reverse osmosis produces a product water which has more of the minerals and salts removed when compared to nanofiltration. At the same time, a reverse osmosis product water is likely to require the addition of more post treatment chemicals in order to provide a finished product suitable for pumping into the distribution system and customer's homes. Reverse Osmosis also requires a higher pressure (more energy) in order to treat the water than does nanofiltration.

Constituent	Raw Water	RO Product Water	Nanofiltration Product Water
Potassium	0.8 mg/l	0.02 mg/l	0.18 mg/l
Sodium	34 mg/l	1.15 mg/l	7.95 mg/l
Magnesium	4.7 mg/l	0.06 mg/l	0.89 mg/l
Calcium	120 mg/l	1.53 mg/l	22.7 mg/l
Alkalinity	357 mg/l	6.55 mg/l	70.8 mg/l
Chloride	69 mg/l	0.87 mg/l	9.3 mg/l
Sulfate	36 mg/l	0.29 mg/l	6.3 mg/l
Total Dissolved Solids	627 mg/l	10.6 mg/l	119.3 mg/l

There are various options available with regard to whether or not to blend a portion of non-membrane treated water with membrane treated water depending upon desired finished water quality and the type of membranes used. Blending may not be desirable at this facility due to the relative amount of iron, color, and naturally occurring organic matter in the raw water. In addition, there are options available for recovering a portion of the water from the first stage concentrate through a second stage system when using R.O. treatment which increases the recovery rate.

**PRELIMINARY ENGINEERING REPORT**  
**PORT OF THE ISLANDS WATER TREATMENT PLANT**  
June 10, 2009  
Page 27

All membrane treatment systems will require some form of pretreatment for the water coming from the wells as well as post-treatment of the membrane treated water. Pretreatment can include a combination of: (1) multi-media filtration, (2) sand separator, (3) carbon filters, (4) cartridge filtration, and (5) iron-removal filters. The raw water will likely require some sort of chemical addition prior to the membrane treatment in order to minimize chemical fouling due to precipitation on the membranes. Degassification to remove carbon dioxide may or may not be needed. Acid addition prior to the membranes for pH adjustment and caustic addition after the membranes will likely be needed. Post-treatment to add calcium back into the product water in order to provide a non-corrosive finished water product is also anticipated, but would depend on the type of membrane as well as potential for blending of non-membrane water with membrane treated water.

A review of the information provided from the three manufacturers suggests that it may be preferred to develop a detailed performance specification and to bid a package water treatment system including installation separate from the construction of the building to house the proposed water treatment plant. In this manner, each supplier would be responsible for the entire system, including pretreatment, feed pumps, membranes, post-treatment, and membrane cleaning systems which they need in order to treat the subject raw water in order to produce a specified finished water quality. The specification would include the amount of finished water required to be produced per minute of operation. These bids would be evaluated based on the installed cost, anticipated operating costs, as well as relative ease of operation of the system. Therefore, the preliminary design provided in this report is based on a review of the various alternative systems identified by the various vendors in such a manner as to provide sufficient room inside the proposed building to house any of the options. A review of the budget pricing provided by the various manufacturers for various major system components was done in order to estimate the approximate cost of the delivered and installed treatment units.

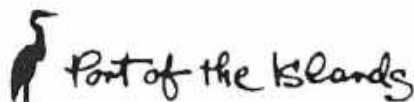

**RECOMMENDED DESIGN AND CONSTRUCTION PROGRAM**

It is recommended that the Port of the Islands CID take the following approach to the design and construction of this water treatment plant.

1. Authorize the preparation of site plan drawings which can be submitted to Collier County along with an application for a Site Development Plan (SDP). It is recommended that this SDP be for the development of the property (existing and any potential adjacent property acquired for stormwater management) for a water treatment and wastewater treatment plant only. This will be consistent with the original Conditional Use zoning for this property in the early 1990's and should not require a rezone at this time. The Collier County SDP process is rather involved and takes time (minimum of six months) to go through County staff review, public information meetings, Planning Commission public hearing, as well as Collier County Board of Commissioners public hearing.
2. Authorize the design of the new water treatment plant. The design will be divided into a few major components.
  - a. Paving, grading, and drainage along with yard piping design will need to be performed simultaneously with preparation of the SDP application package as this information is required with the SDP application.
  - b. Design of the building to house the new water treatment plant will need to be performed simultaneously with preparation of the SDP application package as site plan showing the building dimensions as well as architectural elevations are required with the SDP application.
  - c. Design of the actual water treatment equipment and piping systems within the building is not necessary for SDP review. Any water treatment equipment or structures to be located outside of the building will need to be shown in the SDP drawings in plan view at a minimum and those which are significant will also need elevation views.
  - d. Design of the electrical and control systems for the facility will be done after all of the water treatment systems have been designed.
3. Construction of the facility is recommended to be divided into three contracts.
  - a. The first contract would consist of the site work and building construction. Included in this would be providing electrical service to the new building along with lighting, HVAC, and plumbing. The building would be designed with floor trenches for installation of process piping and with cable trays for installation of electrical wire and conduit (process piping and electrical would be installed under the second contract).
  - b. The second contract would consist of the procurement and installation of the primary water treatment equipment into the building. This would include providing the electrical conduit and wire runs from the equipment to the electrical room along with necessary switchgear and controls.

**PRELIMINARY ENGINEERING REPORT**  
**PORT OF THE ISLANDS WATER TREATMENT PLANT**  
June 10, 2009  
Page 29

- c. The third contract would consist of installation of remaining instrumentation and controls along with development of SCADA system, including integration of existing SCADA for wellfield, wastewater treatment plant, canal pump station, and eventually collection system lift stations into the system. This would include programming as well as procurement and installation of computer processing and monitoring equipment to make the POI utility system a complete functional automated system.

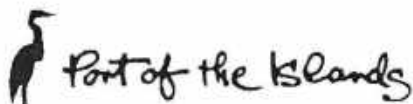

**ESTIMATION OF PROJECT BUDGET**

A preliminary opinion of Engineer's estimate of probable construction cost, based on the preliminary engineering completed to date has been prepared. This estimate has been prepared in a manner such that it should provide a preliminary project budget sufficient to cover anticipated design decisions. It is based on using generally the higher ranges of equipment costs and building size which were identified during preliminary evaluation of various options and systems. There is the potential for possible savings to be realized during detailed design, although this will depend on decisions to be made with regard to establishing minimum design criteria and space planning.

The preliminary construction cost estimate is \$3.7 million. A copy of the preliminary cost estimate is provided.

**PRELIMINARY PROJECT SCHEDULE**

A preliminary opinion of Engineer's estimate of a probable project schedule has been prepared. This schedule has been prepared, based on the outline of design and construction identified above. The schedule has been developed to allow for Collier County Site Development Plan (SDP) permitting to be conducted simultaneous with the detailed design and procurement of membrane treatment system as well as bidding of the construction contract for the building and site work.

This schedule identifies that with design beginning in mid-July 2009 that the new WTP could be complete and operational by January 2011 at the earliest, for a total design and construction period of 18 months. While it may be possible to expedite this schedule, it is believed that for planning purposes that this schedule identifies the earliest which the facility can be anticipated as being completed. In the event that the CID were to need to provide a completion deadline to FDEP (or other agency) it is suggested that a time of 24 months be used to allow for a contingency for any unforeseen permitting or construction issues.

The current Capital Improvement Program (CIP) identifies that preliminary design (related to preparation of minimum design required for applying for Collier County SDP) be performed during FY2010, detailed design performed during FY2011, and construction of this project to be performed during FY2012.



**PRELIMINARY ESTIMATE OF CONSTRUCTION COSTS  
NEW WATER TREATMENT PLANT  
PORT OF THE ISLANDS CID  
Collier County, Florida**

**CONSTRUCTION**

1	Membrane Equip-Furnish	\$450,000
2	Membrane Pretreatment Equip-Furnish	\$150,000
3	Post Treatment Equipment-Furnish	\$100,000
4	Install Membrane Equipment	\$125,000
5	Chlorine Contact Chamber	\$90,000
6	Transfer Pumps w/piping	\$90,000
7	High Service Pump Chamber	\$80,000
8	High Service Pumps w/piping	\$90,000
9	Yard Piping	\$75,000
10	Interior Piping	\$110,000
11	Building - 8,625 sf	\$1,120,000
12	Additional Building Cost for Pipe Trenches & Grating	\$50,000
13	Electrical & Instrumentation @20%	\$506,000
14	Misc Site Work and Grading	\$40,000
15	Allowance for Paving - 1,000 sy	\$40,000
16	Allowance for Fencing and Site Improvements	\$20,000
	Subtotal	<u>\$3,136,000</u>
	Contingency at 20%	\$630,000
	<b>Total Construction Cost</b>	<u><b>\$3,766,000</b></u>

## Note:

- 1 Contingency and Total have been rounded.

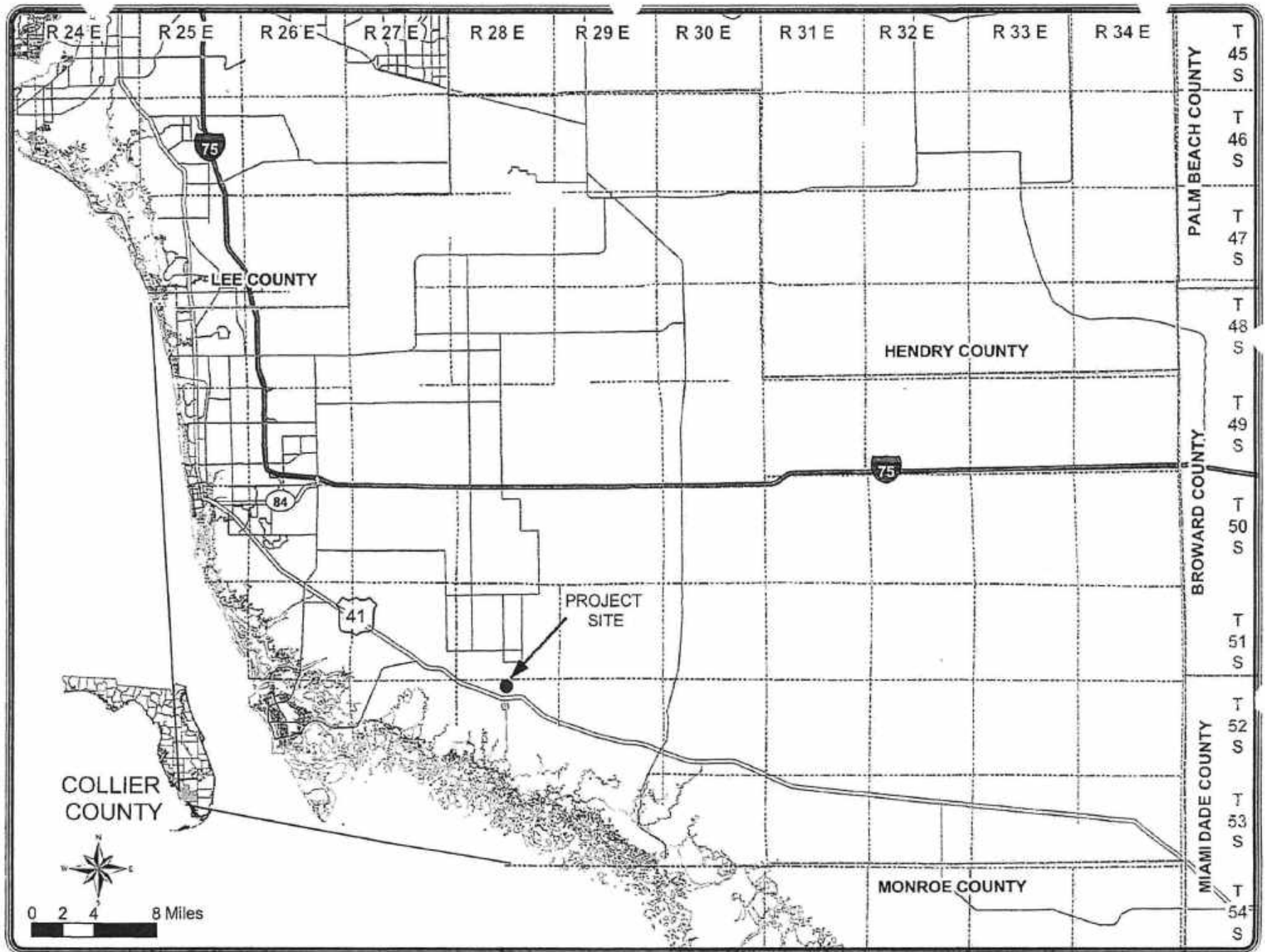

FIGURE 1-1. MAP SHOWING LOCATION OF PROJECT SITE.

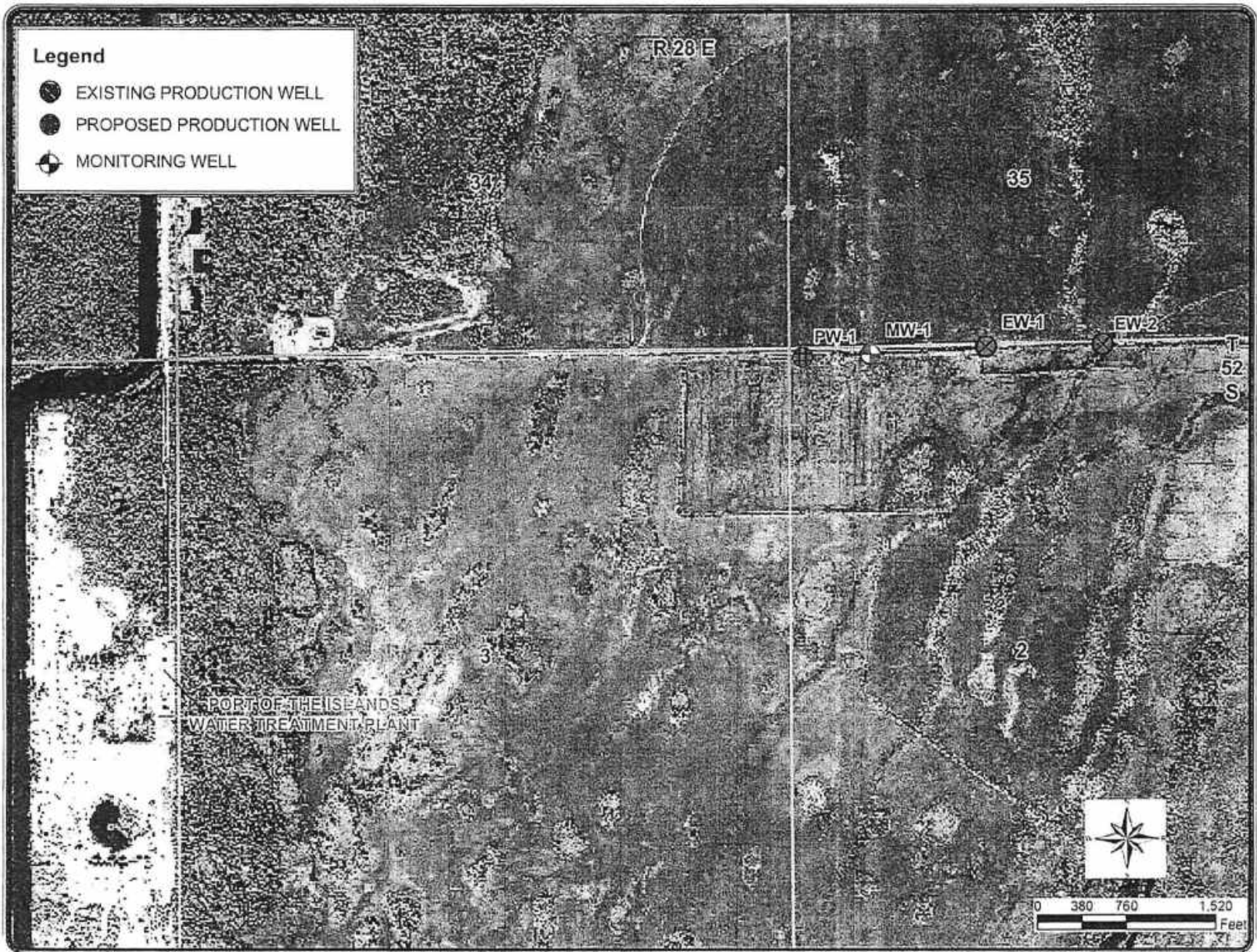
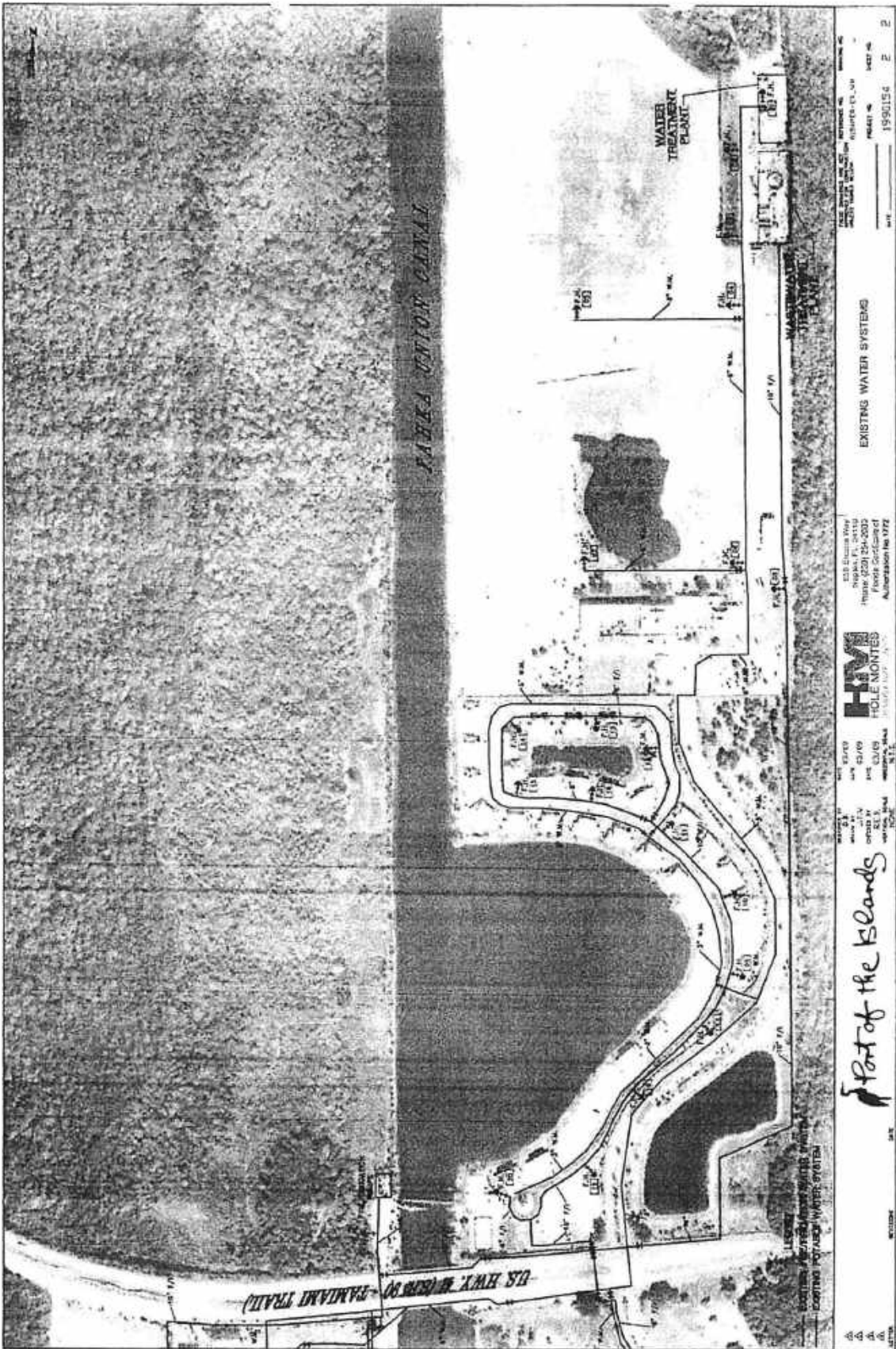

FIGURE 2-1. AERIAL PHOTO SHOWING LOCATION OF PROPOSED FACILITIES FOR PORT OF THE ISLANDS WELLFIELD.







PARKS UNION CANAL

WATER TREATMENT PLANT

EXISTING WATER SYSTEMS

EXISTING POTABLE WATER SYSTEM



HW  
FOLE MONTEZ  
ENGINEERS, INC.  
1000 N. 10TH ST.  
TUCSON, AZ 85710

*Part of the Islands*

DATE: 02/09  
SCALE: AS SHOWN  
PROJECT NO.: 1990154  
SHEET NO.: 2 OF 2

H:\2008\20080201\WATER\PORT OF THE ISLANDS\PORT OF THE ISLANDS.dwg, 6/10/2008 4:52:38 PM

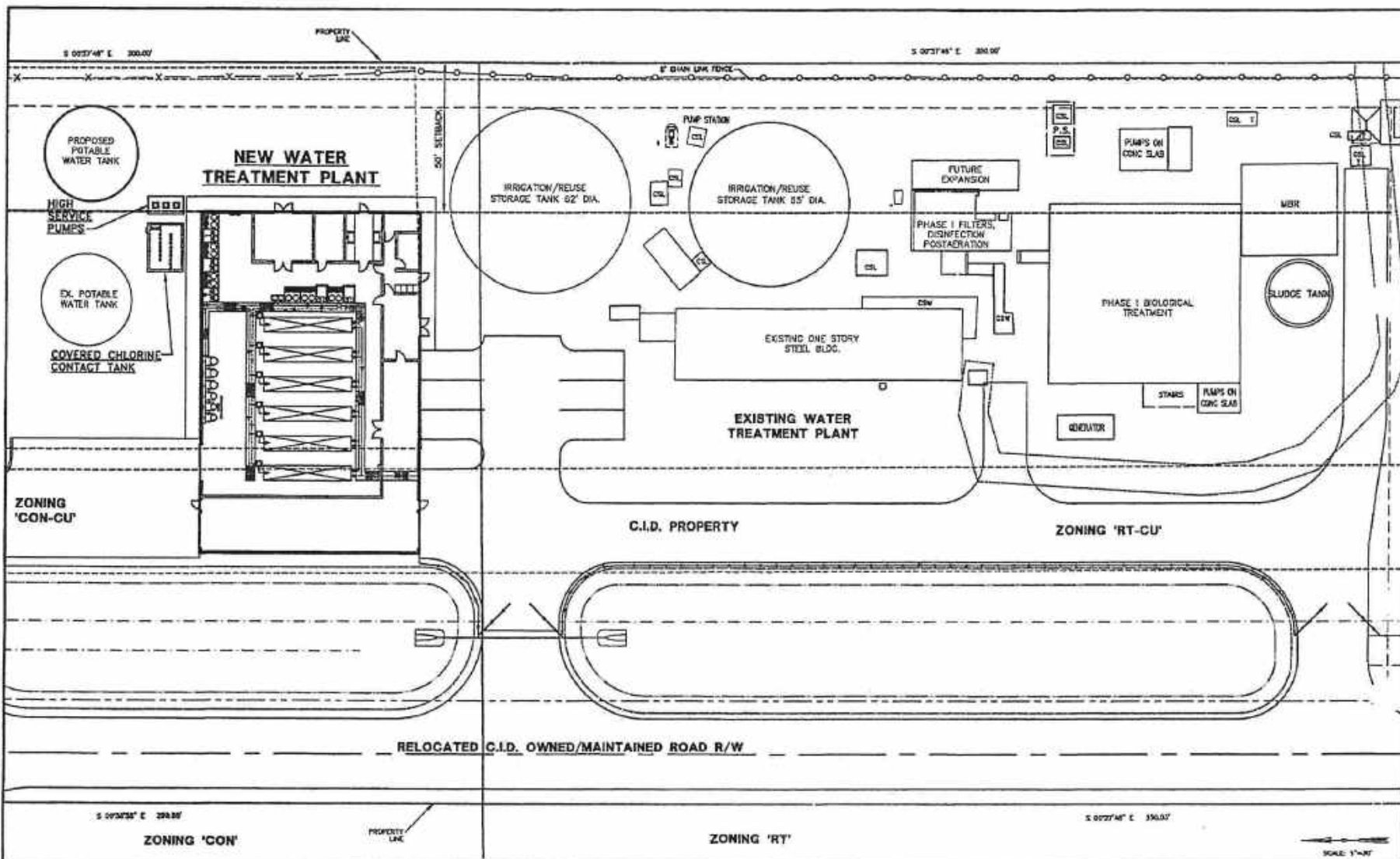

NO.	REVISION	DATE
1		
2		
3		
4		
5		

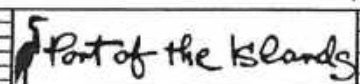

DESIGNED BY	JIT	DATE	01/07
DRAWN BY	JTF	DATE	01/07
CHECKED BY	AKB	DATE	06/07
VERTICAL SCALE		REDUCING SCALE	AS SHOWN

**HM**  
HOLE MONTES  
ENGINEERS-PLANNERS-ARCHITECTS  
UNIVERSITY PROJECTS

950 Encore Way  
Naples, FL 34110  
Phone: (239) 264-2000  
Florida Certificate of  
Authorization No. 1772

**PORT OF THE ISLANDS WATER TREATMENT PLANT  
PROPOSED MEMBRANE SOFTENING**

**EXHIBIT 1**















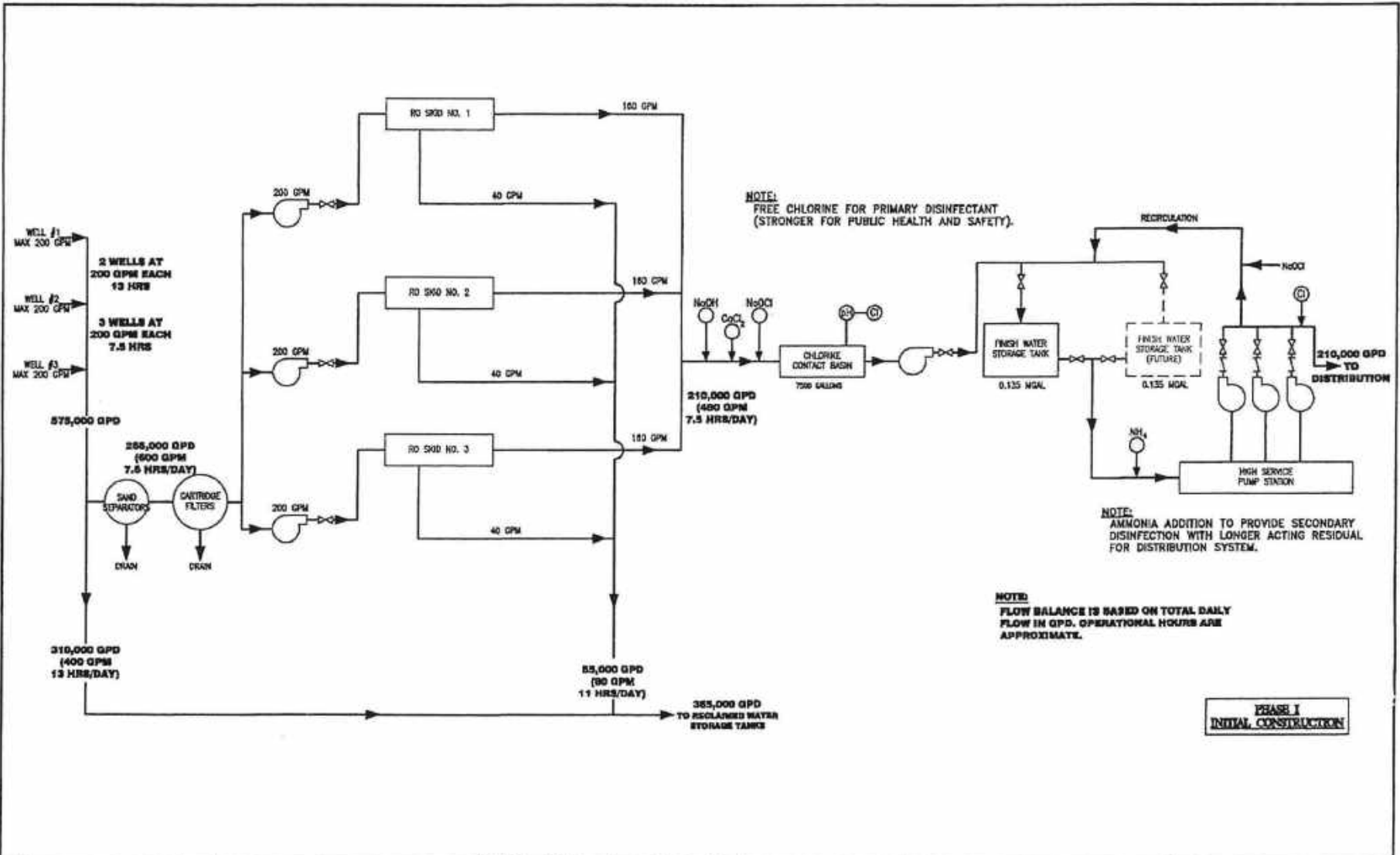

H:\2005\20050920\PORT OF THE ISLANDS\06020071\_01.dwg, 8/12/2005 4:20:52 PM

1		
2		
3		
4		
5		
6		
7		
8		
9		
10		
11		
12		
13		
14		
15		
16		
17		
18		
19		
20		
21		
22		
23		
24		
25		
26		
27		
28		
29		
30		
31		
32		
33		
34		
35		
36		
37		
38		
39		
40		
41		
42		
43		
44		
45		
46		
47		
48		
49		
50		
51		
52		
53		
54		
55		
56		
57		
58		
59		
60		
61		
62		
63		
64		
65		
66		
67		
68		
69		
70		
71		
72		
73		
74		
75		
76		
77		
78		
79		
80		
81		
82		
83		
84		
85		
86		
87		
88		
89		
90		
91		
92		
93		
94		
95		
96		
97		
98		
99		
100		

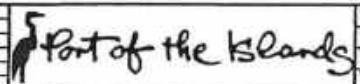

DESIGNED BY	RET	DATE	04/9
DRAWN BY	SEP	DATE	04/9
CHECKED BY	RET	DATE	04/9
PROJECT NO.		ISSUE NO.	



850 Encore Way  
Naples, FL 34110  
Phone: (239) 254-2000  
Florida Certificate of  
Authorization No. 1772

**PORT OF THE ISLANDS WATER  
TREATMENT PLANT  
PROPOSED MEMBRANE SOFTENING**

**EXHIBIT 7**



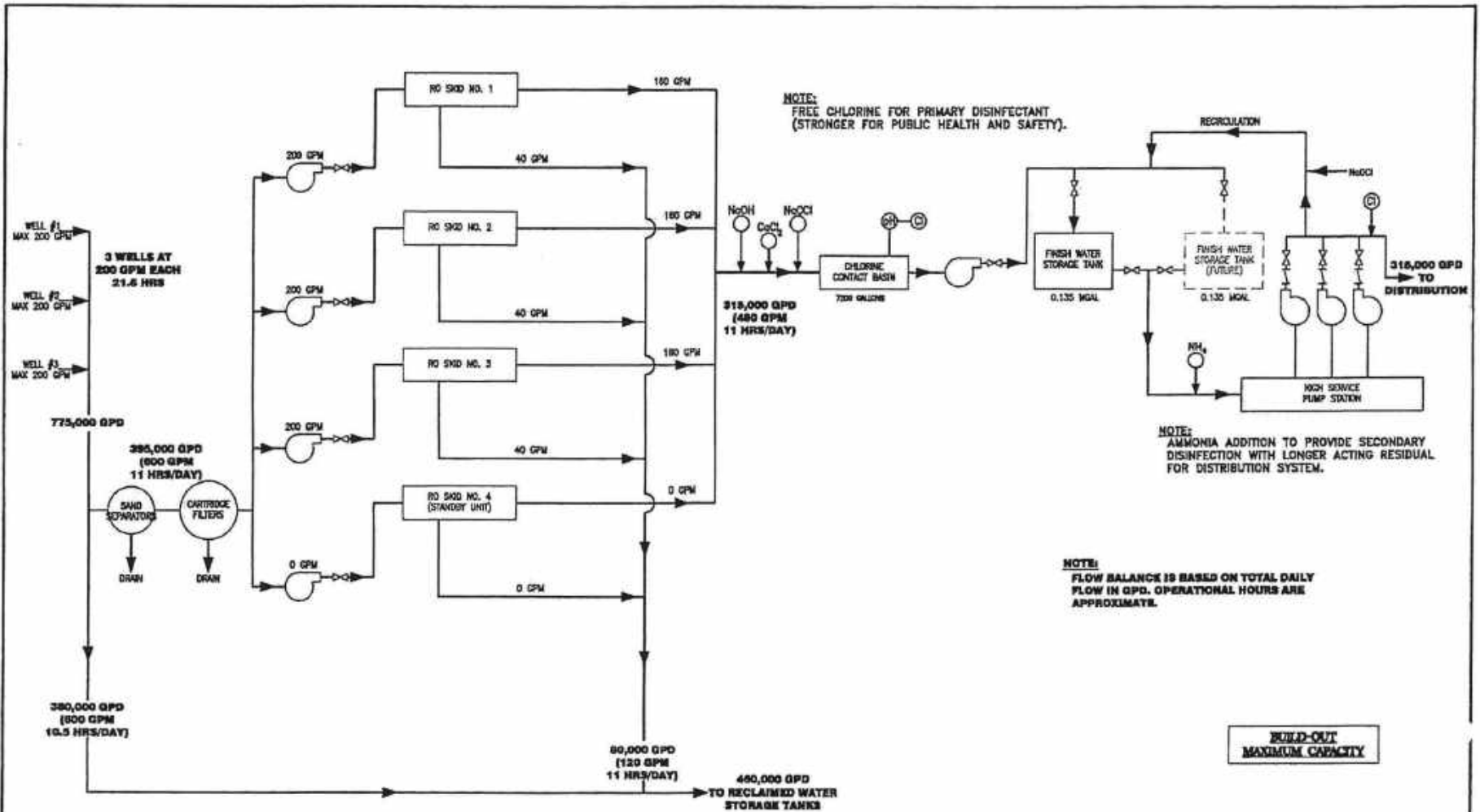

11/20/2010 10:09:00 AM 148135014112100029/PT\_24-6.dwg 11/2/2010 4:01:50 PM

1		
2		
3		
4		
5		
6		
7		
8		
9		
10		
11		
12		
13		
14		
15		
16		
17		
18		
19		
20		
21		
22		
23		
24		
25		
26		
27		
28		
29		
30		
31		
32		
33		
34		
35		
36		
37		
38		
39		
40		
41		
42		
43		
44		
45		
46		
47		
48		
49		
50		

**Part of the Islands**

DESIGNED BY	JHT	DATE	04/19
DRAWN BY	CCP	DATE	04/19
CHECKED BY	KEP	DATE	04/19
VERTICAL SCALE	NONE	HORIZONTAL SCALE	1/4"=1'

**HM HOLE MONTES**  
 930 Encove Way  
 Naples, FL 34110  
 Phone: (239) 254-2000  
 Florida Certificate of  
 Authorization No. 1772

**PORT OF THE ISLANDS WATER  
 TREATMENT PLANT  
 PROPOSED MEMBRANE SOFTENING**

**TENTATIVE PROJECT SCHEDULE  
NEW WATER TREATMENT PLANT  
PORT OF THE ISLANDS COMMUNITY IMPROVEMENT DISTRICT**

**HOLE MONTES INC.  
June 19, 2009**

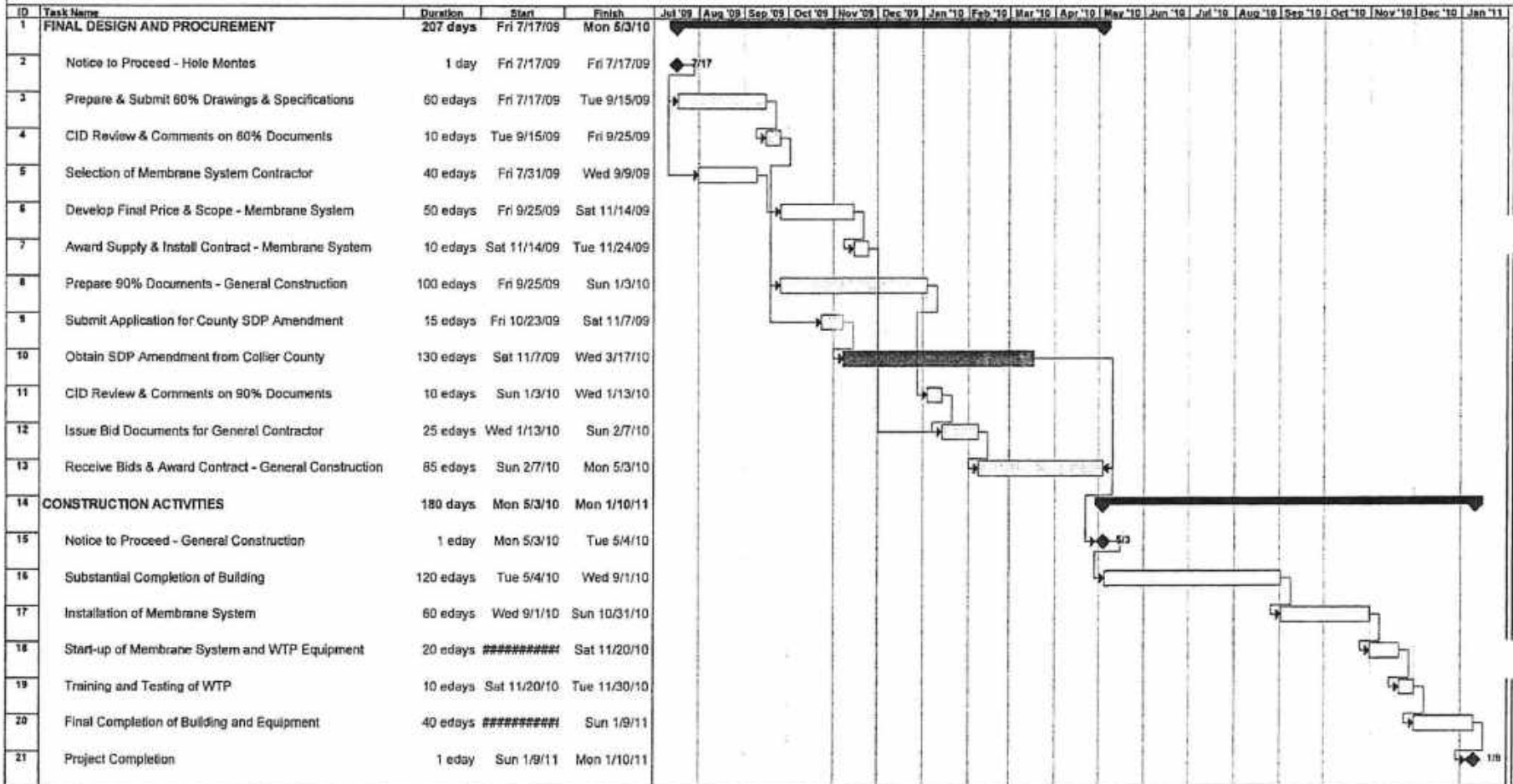

edays = WORK DAYS

